

TAG	X LOC	Y LOC	SIZE
A1	.250	.500	Ø .2010 THRU ALL 1/4-20 UNC THRU ALL
A2	1.250	.500	Ø .2010 THRU ALL 1/4-20 UNC THRU ALL

TAG	X LOC	Y LOC	SIZE
1	1.250	-.750	Ø .0890 THRU ALL 4-40 UNC THRU ALL
2	1.250	-.250	Ø .0890 THRU ALL 4-40 UNC THRU ALL

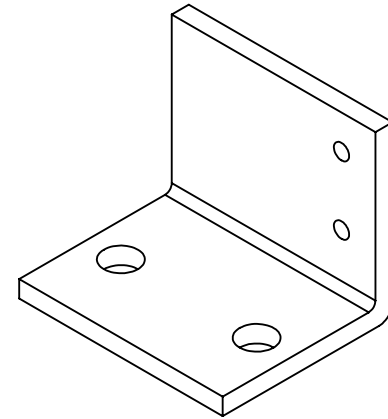
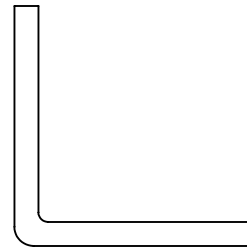
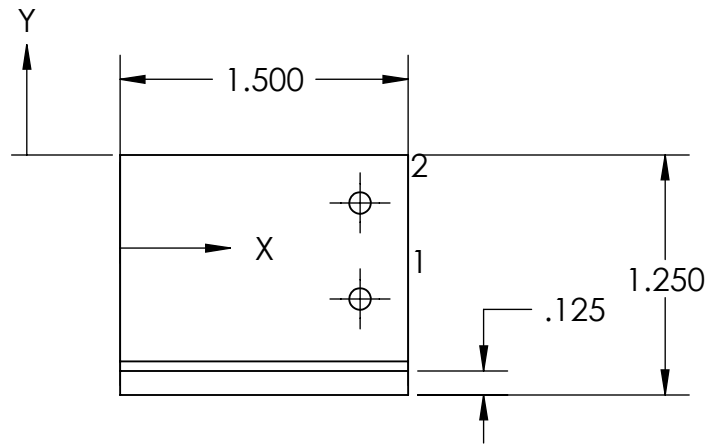
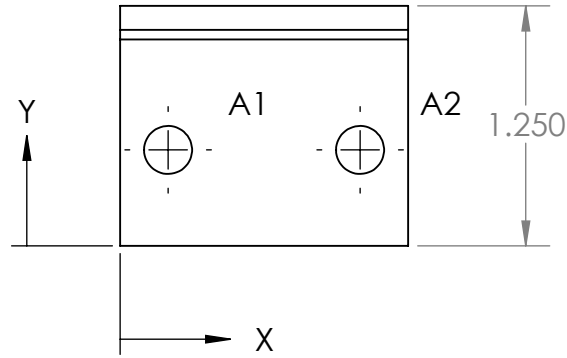

PROPRIETARY AND CONFIDENTIAL
 THE INFORMATION CONTAINED IN THIS DRAWING IS THE SOLE PROPERTY OF <INSERT COMPANY NAME HERE>. ANY REPRODUCTION IN PART OR AS A WHOLE WITHOUT THE WRITTEN PERMISSION OF <INSERT COMPANY NAME HERE> IS PROHIBITED.

		UNLESS OTHERWISE SPECIFIED:		NAME	DATE	TITLE: P11213 - Effector Mount
		DIMENSIONS ARE IN INCHES	DRAWN	AJK		
		TOLERANCES: FRACTIONAL ±	CHECKED	DAR		
		ANGULAR: MACH ± BEND ± TWO PLACE DECIMAL ± THREE PLACE DECIMAL ±	ENG APPR.			
		INTERPRET GEOMETRIC TOLERANCING PER:	MFG APPR.			SIZE DWG. NO. REV
		MATERIAL	Q.A.			
NEXT ASSY	USED ON	FINISH	COMMENTS: Made from angle steel			SCALE: 1:1 WEIGHT: SHEET 1 OF 1
APPLICATION		DO NOT SCALE DRAWING				