

| TAG | X LOC | Y LOC | SIZE |
|-----|-------|-------|---|
| A1 | .250 | .250 | Ø .2010 THRU ALL 1/4-20 UNC THRU ALL |
| A2 | 1.250 | .250 | Ø .2010 THRU ALL 1/4-20 UNC THRU ALL |

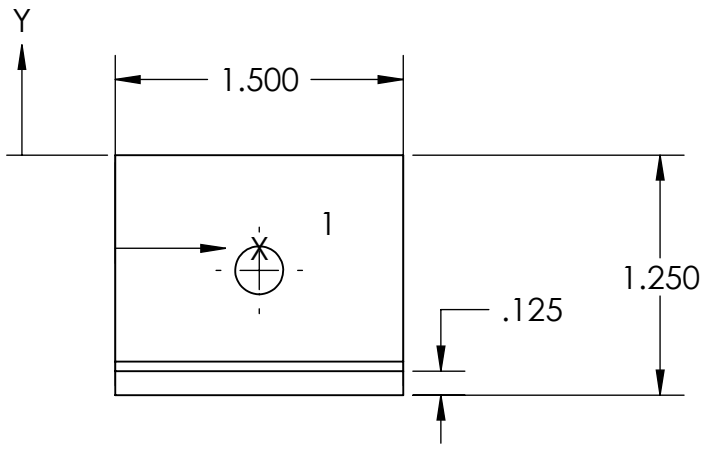

| TAG | X LOC | Y LOC | SIZE |
|-----|-------|--------|------------------|
| 1 | .7500 | -.6000 | Ø .2500 THRU ALL |

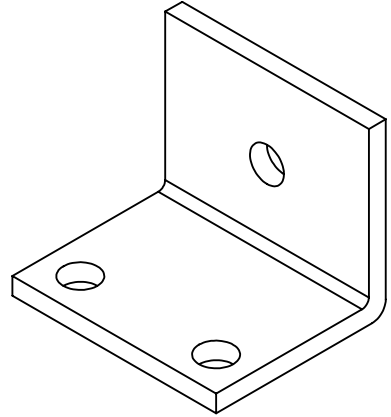
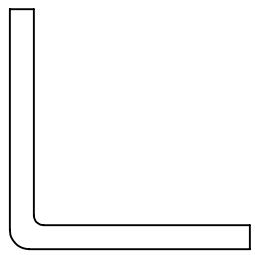

PROPRIETARY AND CONFIDENTIAL
 THE INFORMATION CONTAINED IN THIS DRAWING IS THE SOLE PROPERTY OF <INSERT COMPANY NAME HERE>. ANY REPRODUCTION IN PART OR AS A WHOLE WITHOUT THE WRITTEN PERMISSION OF <INSERT COMPANY NAME HERE> IS PROHIBITED.

| | | UNLESS OTHERWISE SPECIFIED: | NAME | DATE |
|-------------|---------|--------------------------------------|------------------|------|
| | | DIMENSIONS ARE IN INCHES | DRAWN | AJK |
| | | TOLERANCES: | CHECKED | DAR |
| | | FRACTIONAL ± | ENG APPR. | |
| | | ANGULAR: MACH ± BEND ± | MFG APPR. | |
| | | TWO PLACE DECIMAL ± | Q.A. | |
| | | THREE PLACE DECIMAL ± | COMMENTS: | |
| | | INTERPRET GEOMETRIC TOLERANCING PER: | From angle steel | |
| | | MATERIAL | | |
| NEXT ASSY | USED ON | FINISH | | |
| APPLICATION | | DO NOT SCALE DRAWING | | |

| | | |
|-----------------------|----------|--------------|
| TITLE: | | |
| P11213 - Pinned Mount | | |
| SIZE | DWG. NO. | REV |
| A | | |
| SCALE: 1:1 | WEIGHT: | SHEET 1 OF 1 |