

SCALE 0.500

| | | | | | |
|---------------------------------|------|-----------|-------------------------|-----------------------|-------|
| GENERAL TOLERANCES UNLESS NOTED | | | N.S.S.P.C.M. | | |
| .XXX | .XX | ANGLES | | | |
| 0.050 | 0.10 | 0.50 | MODEL | | |
| DRAWN | | DATE | CRADLE_BOLT_SIDE | | |
| D.E.LUCAS | | Apr-26-12 | | | |
| CHECKED | | DATE | SIZE | DRAWING NAME | |
| | | | B | MASTER_DRAWING | |
| APPROVED | | DATE | SCALE | MATERIAL | SHEET |
| | | | 0.250 | ALUMINUM | 1/12 |

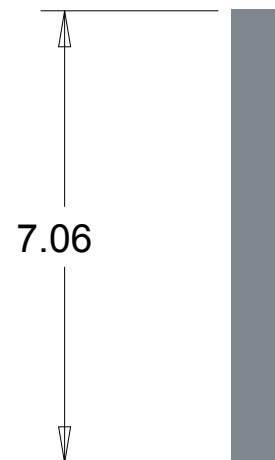
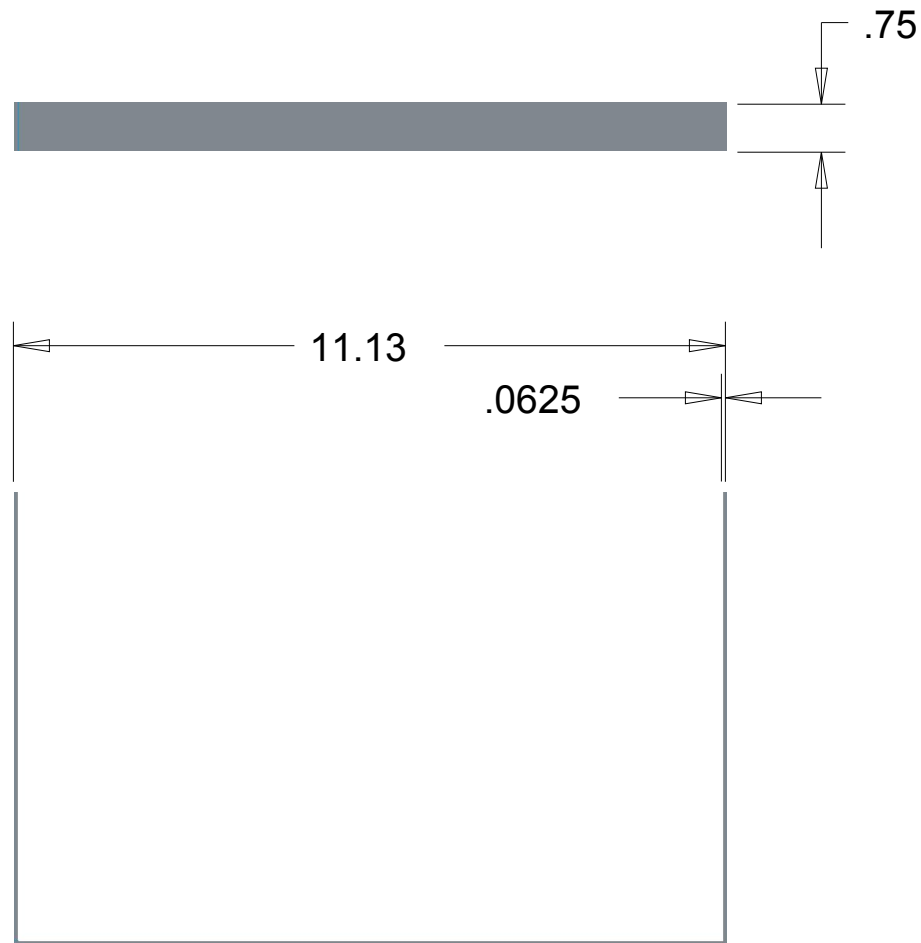

SCALE 0.500

| | | | | | |
|---------------------------------|------|-----------|---------------------|----------------|-------|
| GENERAL TOLERANCES UNLESS NOTED | | | N.S.S.P.C.M. | | |
| .XXX | .XX | ANGLES | | | |
| 0.050 | 0.10 | 0.50 | MODEL | | |
| DRAWN | | DATE | CRADLE_ENDS | | |
| D.E.LUCAS | | Apr-26-12 | | | |
| CHECKED | | DATE | SIZE | DRAWING NAME | |
| | | | B | MASTER_DRAWING | |
| APPROVED | | DATE | SCALE | MATERIAL | SHEET |
| | | | 0.333 | ALUMINUM | 2/12 |

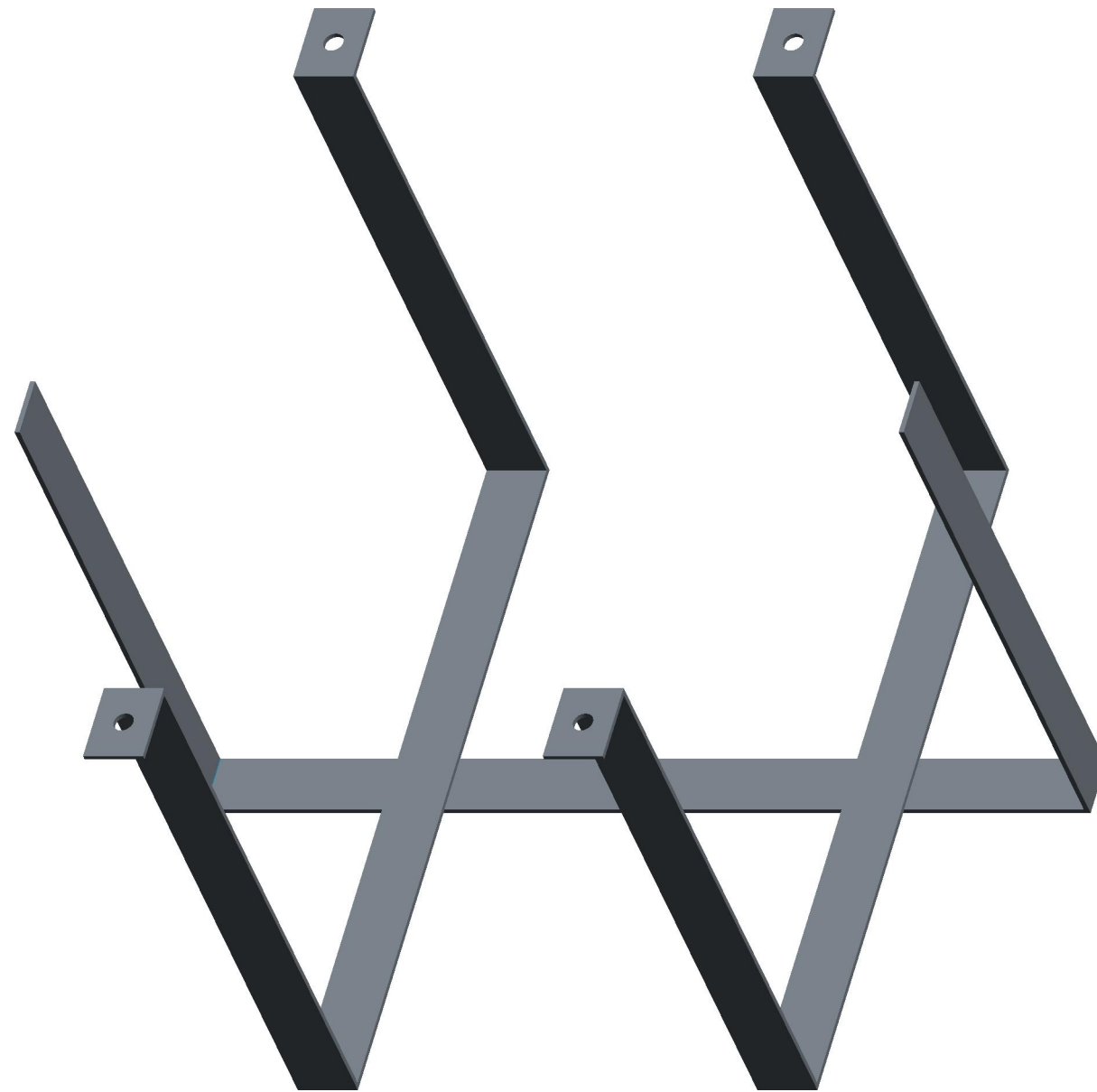

| | | |
|---------------------------------|-----------|--------|
| GENERAL TOLERANCES UNLESS NOTED | | |
| .XXX | .XX | ANGLES |
| 0.050 | 0.10 | 0.50 |
| DRAWN | DATE | |
| D.E.LUCAS | Apr-26-12 | |
| CHECKED | DATE | |
| APPROVED | DATE | |

| | | |
|------------------------|----------------|-------|
| N.S.S.P.C.M. | | |
| MODEL CRADLE | | |
| SIZE | DRAWING NAME | |
| B | MASTER_DRAWING | |
| SCALE | MATERIAL | SHEET |
| 0.500 | ALUMINUM | 3/12 |

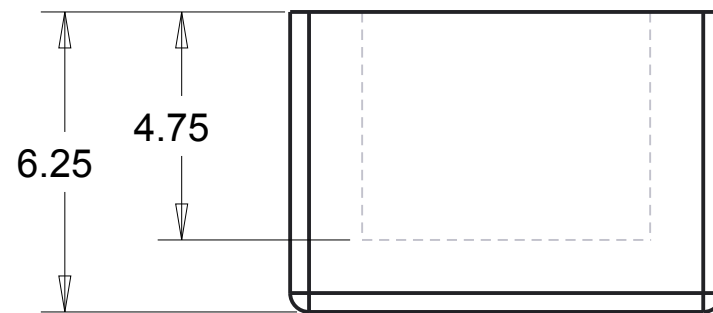
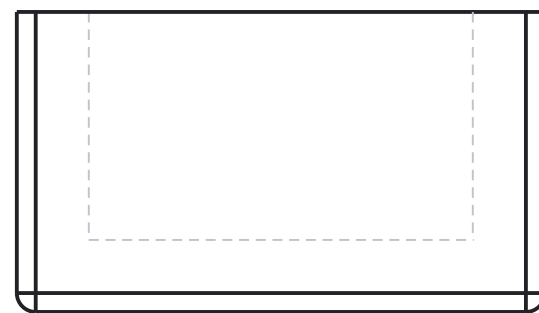
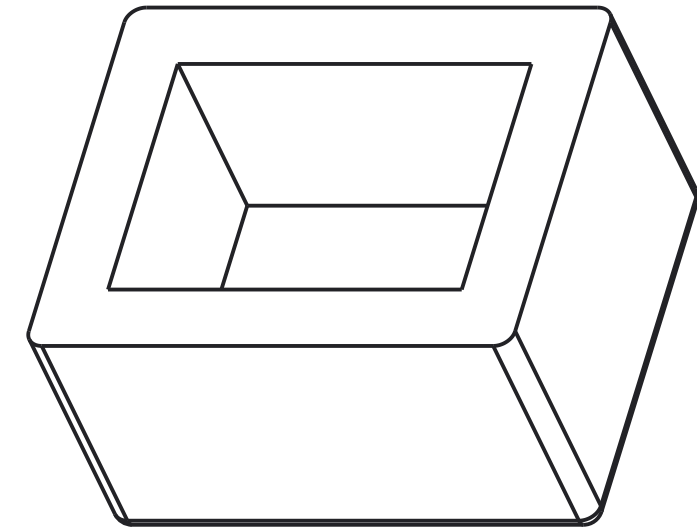
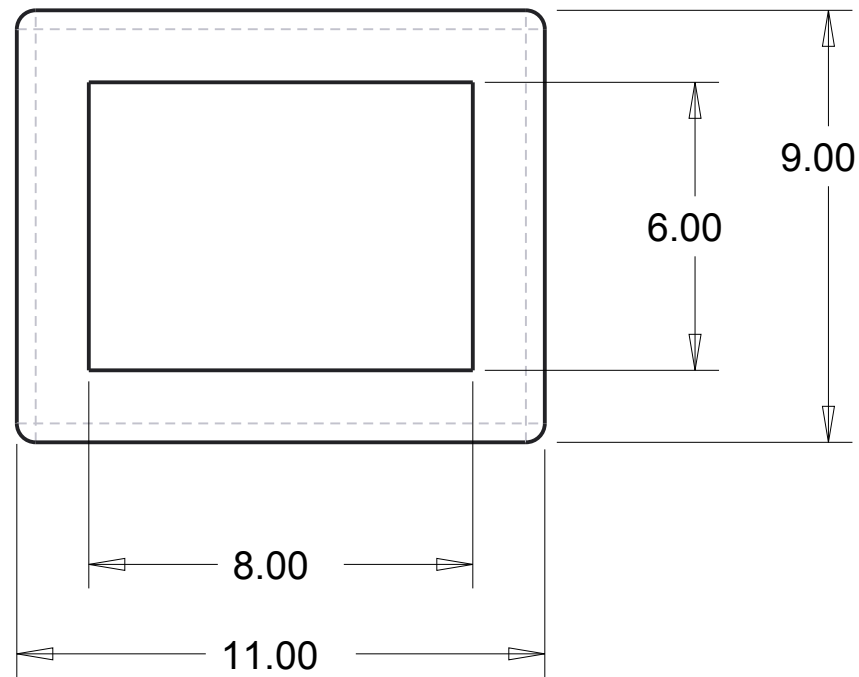

| | | | | | |
|----------------------------------------------------|--|-------------------|---------------------------|--------------------------------|---------------|
| GENERAL TOLERANCES UNLESS NOTED .XXX .XX ANGLES | | | N.S.S.P.C.M. | | |
| 0.050 0.10 0.50 | | | | | |
| DRAWN D.E.LUCAS | | DATE Apr-26-12 | MODEL ENCLOSURE | | |
| CHECKED | | DATE | SIZE B | DRAWING NAME MASTER_DRAWING | |
| APPROVED | | DATE | SCALE 0.250 | MATERIAL POLYSTYRENE | SHEET 4/12 |

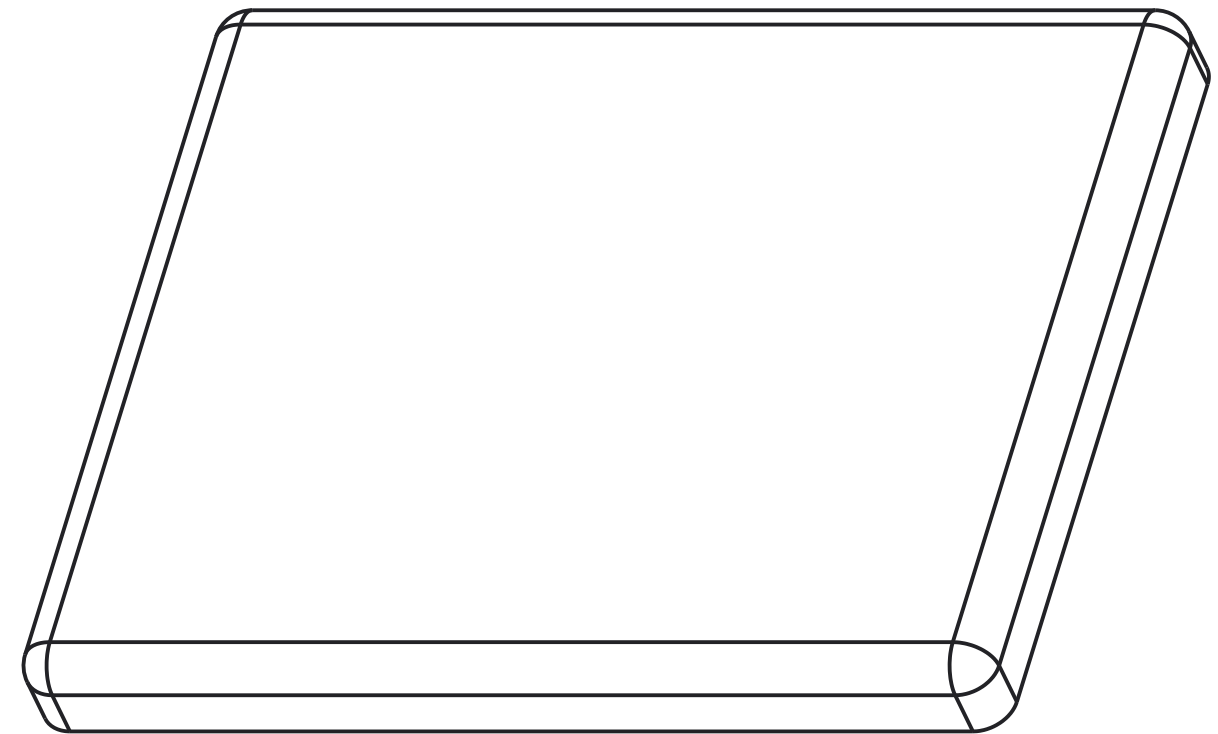
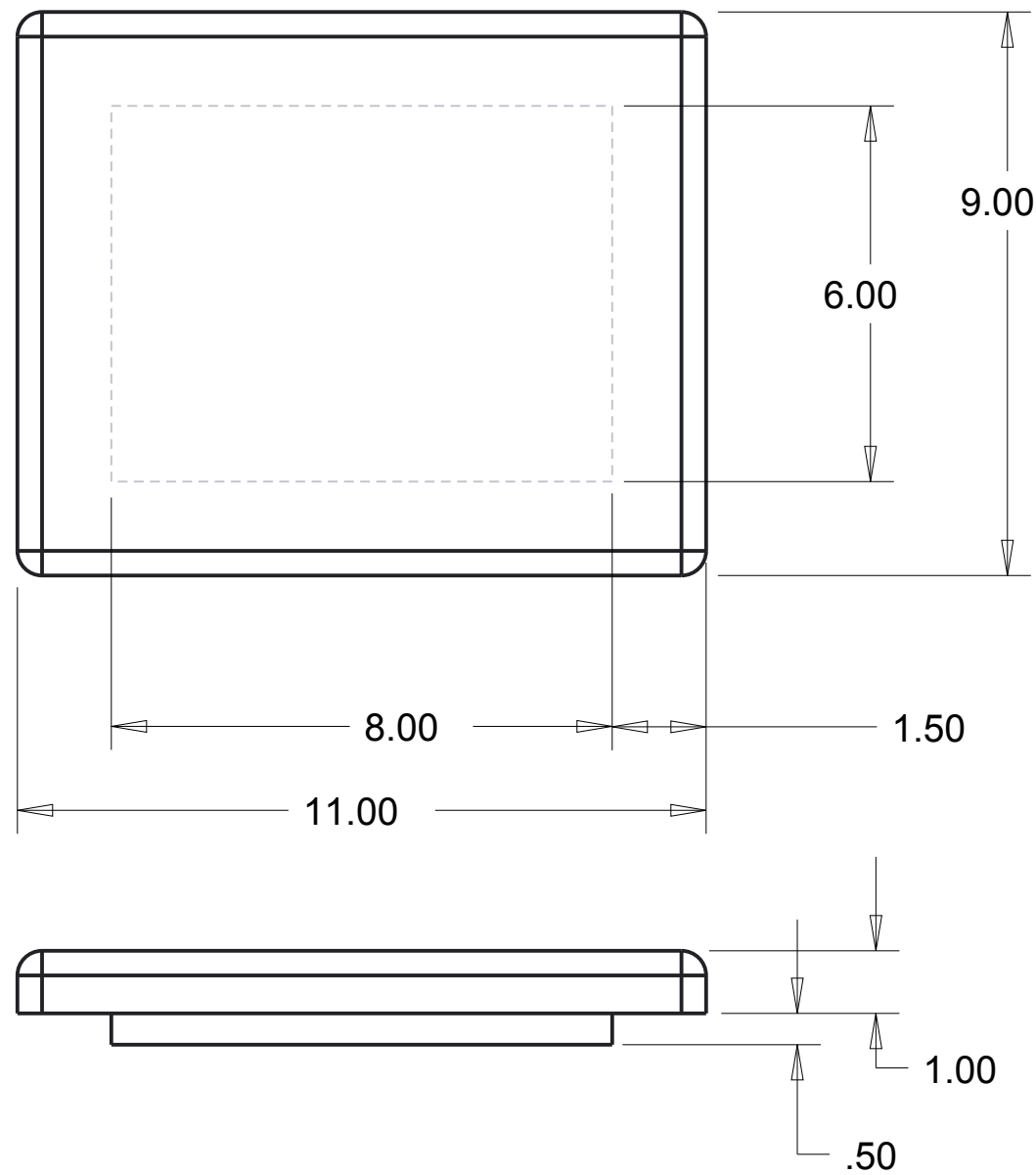

SCALE 0.500

| | | |
|---------------------------------|-----------|--------|
| GENERAL TOLERANCES UNLESS NOTED | | |
| .XXX | .XX | ANGLES |
| 0.050 | 0.10 | 0.50 |
| DRAWN | DATE | |
| D.E.LUCAS | Apr-26-12 | |
| CHECKED | DATE | |
| APPROVED | DATE | |

N.S.S.P.C.M.

MODEL

ENCLOSURE_LID

SIZE
B

DRAWING NAME

MASTER_DRAWING

SCALE 0.333

MATERIAL **POLYSTYRENE**

SHEET 5/12

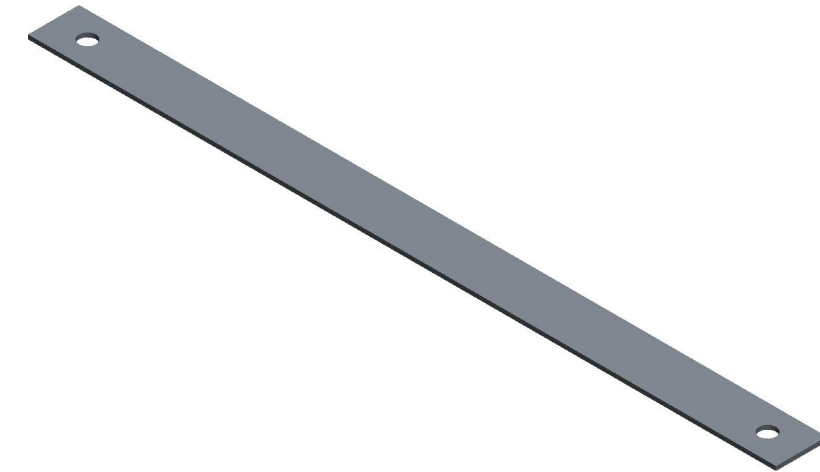

| | | | | | |
|----------------------------------------------------|--|-------------------|---------------------|--------------------------------|---------------|
| GENERAL TOLERANCES UNLESS NOTED .XXX .XX ANGLES | | | N.S.S.P.C.M. | | |
| 0.050 0.10 0.50 | | | | | |
| DRAWN D.E.LUCAS | | DATE Apr-26-12 | MODEL FRAME_11 | | |
| CHECKED | | DATE | SIZE B | DRAWING NAME MASTER_DRAWING | |
| APPROVED | | DATE | SCALE 0.500 | MATERIAL ALUMINUM | SHEET 6/12 |

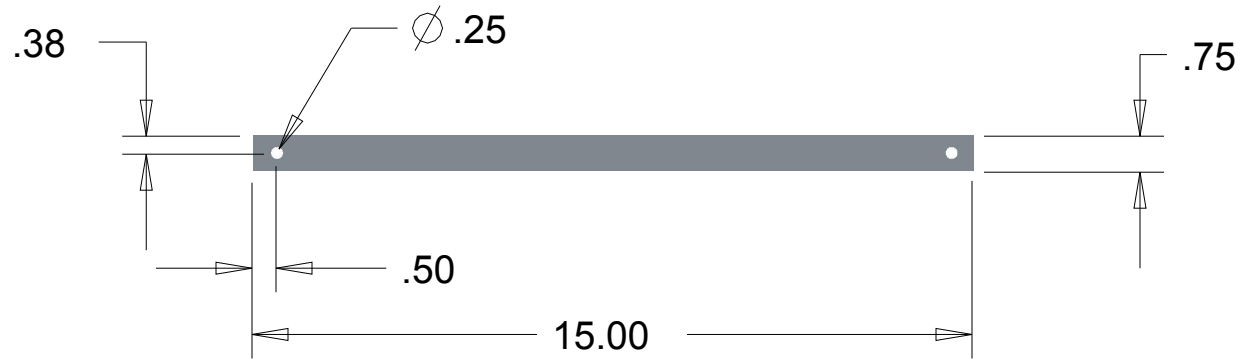

SCALE 0.500



| | | | | | |
|----------------------------------------------------|--|-------------------|--------------------------|---------------------------------------|------------|
| GENERAL TOLERANCES UNLESS NOTED .XXX .XX ANGLES | | | N.S.S.P.C.M. | | |
| 0.050 0.10 0.50 | | | | | |
| DRAWN D.E.LUCAS | | DATE Apr-26-12 | MODEL FRAME_15 | | |
| CHECKED | | DATE | | | |
| APPROVED | | DATE | SIZE B | DRAWING NAME MASTER_DRAWING | |
| | | | SCALE 0.250 | MATERIAL ALUMINUM | SHEET 7/12 |

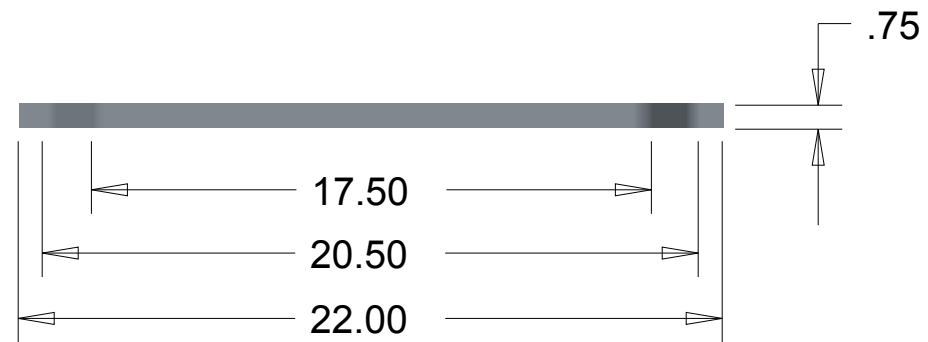

SCALE 0.400

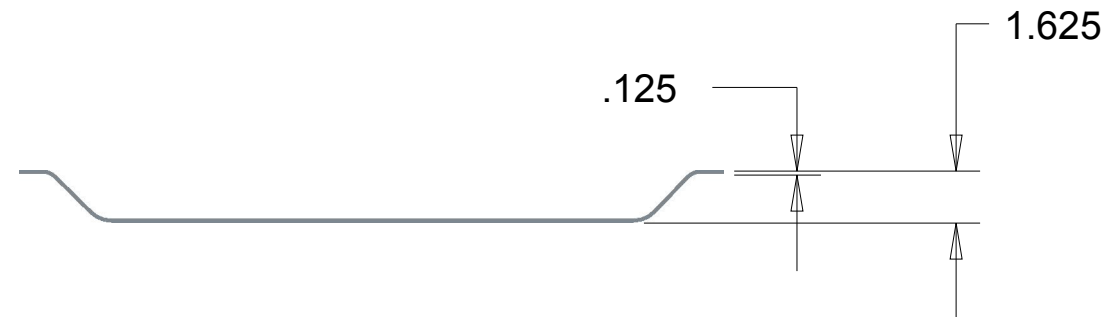

| | | | | | |
|----------------------------------------------------|--|-------------------|-----------------------------|---------------------------------------|------------|
| GENERAL TOLERANCES UNLESS NOTED .XXX .XX ANGLES | | | N.S.S.P.C.M. | | |
| 0.050 0.10 0.50 | | | | | |
| DRAWN D.E.LUCAS | | DATE Apr-26-12 | MODEL FRAME_CROSS | | |
| CHECKED | | DATE | | | |
| APPROVED | | DATE | SIZE B | DRAWING NAME MASTER_DRAWING | |
| | | | SCALE 0.167 | MATERIAL ALUMINUM | SHEET 8/12 |

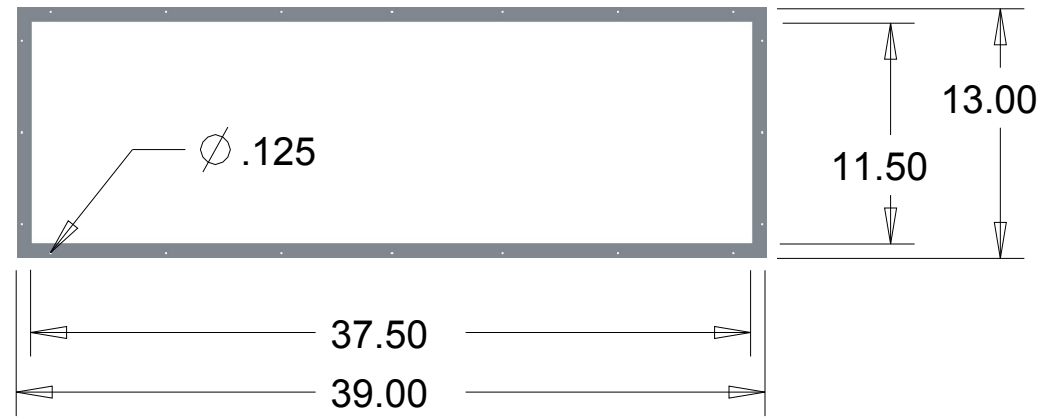

SCALE 0.125



| | | | | | |
|----------------------------------------------------|--|-------------------|----------------------|--------------------------------|------------|
| GENERAL TOLERANCES UNLESS NOTED .XXX .XX ANGLES | | | N.S.S.P.C.M. | | |
| 0.050 0.10 0.50 | | | | | |
| DRAWN D.E.LUCAS | | DATE Apr-26-12 | MODEL PANEL_UNDER | | |
| CHECKED | | DATE | SIZE B | DRAWING NAME MASTER_DRAWING | |
| APPROVED | | DATE | SCALE 0.100 | MATERIAL ALUMINUM | SHEET 9/12 |

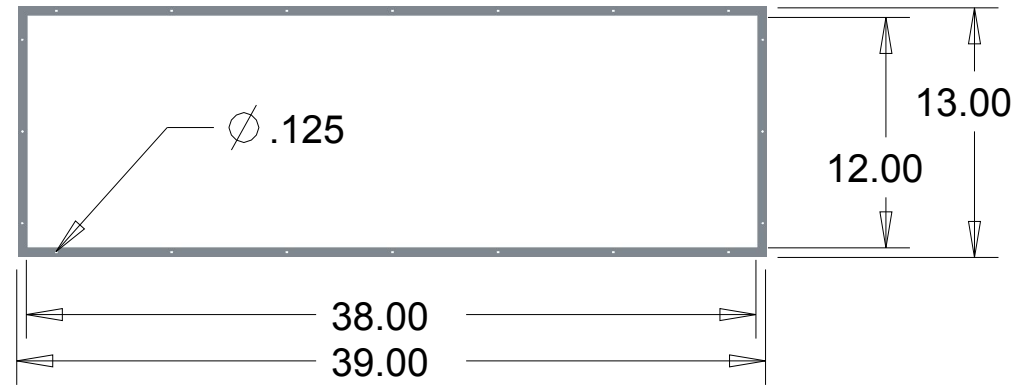

SCALE 0.125



| | | | | | |
|----------------------------------------------------|--|-------------------|---------------------|--------------------------------|-------------|
| GENERAL TOLERANCES UNLESS NOTED .XXX .XX ANGLES | | | N.S.S.P.C.M. | | |
| 0.050 0.10 0.50 | | | | | |
| DRAWN D.E.LUCAS | | DATE May-01-12 | MODEL PANEL_OVER | | |
| CHECKED | | DATE | SIZE B | DRAWING NAME MASTER_DRAWING | |
| APPROVED | | DATE | SCALE 0.100 | MATERIAL ALUMINUM | SHEET 10/12 |

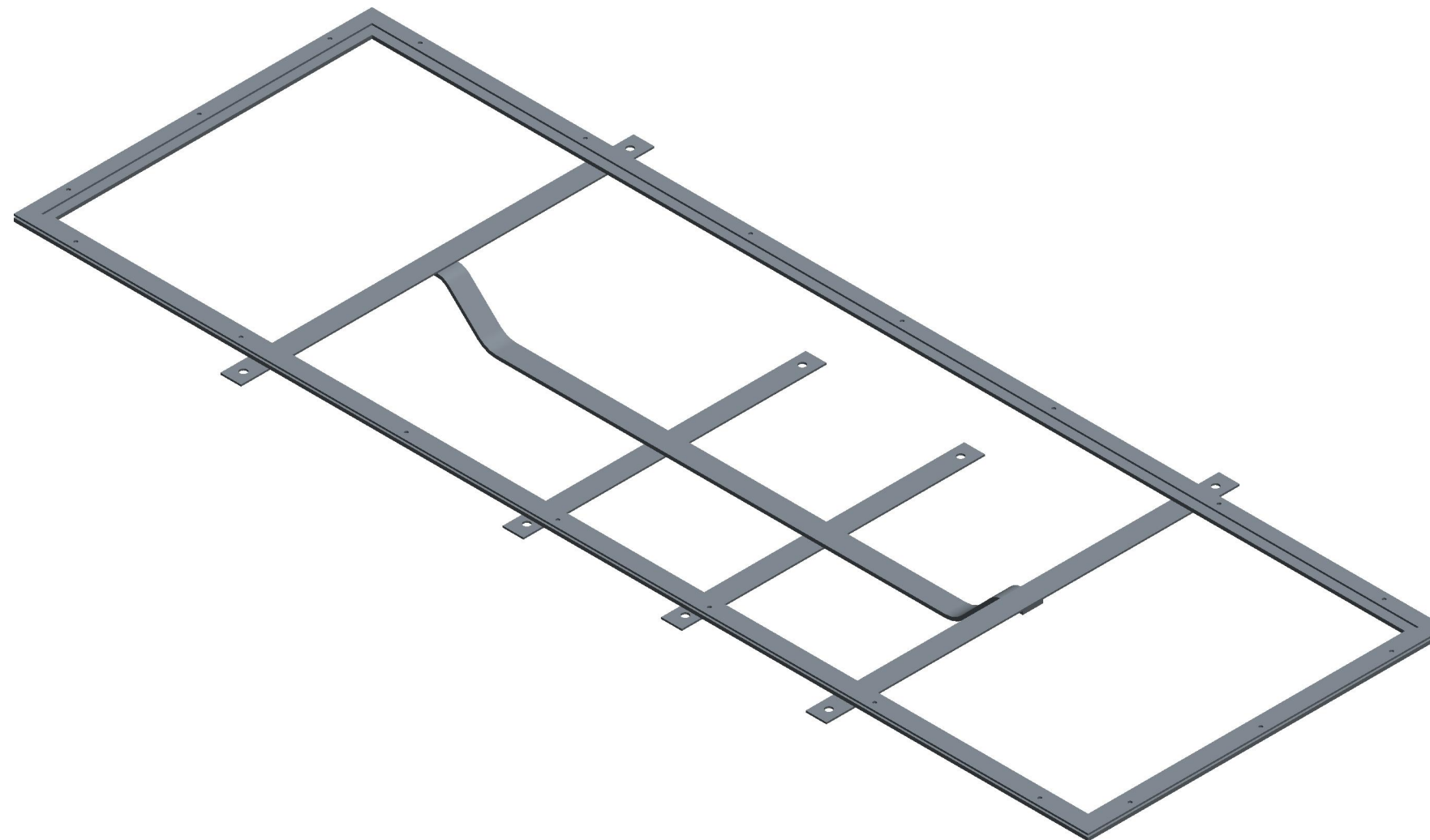

| | | | | | |
|----------------------------------------------------|--|-------------------|-----------------------------|--------------------------------|-------------|
| GENERAL TOLERANCES UNLESS NOTED .XXX .XX ANGLES | | | N.S.S.P.C.M. | | |
| 0.050 0.10 0.50 | | | | | |
| DRAWN D.E.LUCAS | | DATE May-01-12 | MODEL PANEL_MOUNT | | |
| CHECKED | | DATE | | | |
| APPROVED | | DATE | SIZE B | DRAWING NAME MASTER_DRAWING | |
| | | | SCALE 0.250 | MATERIAL ALUMINUM | SHEET 11/12 |

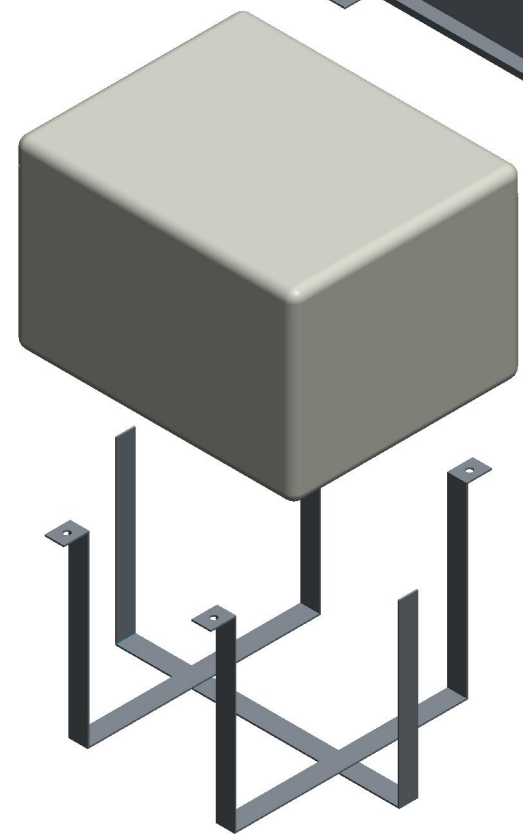
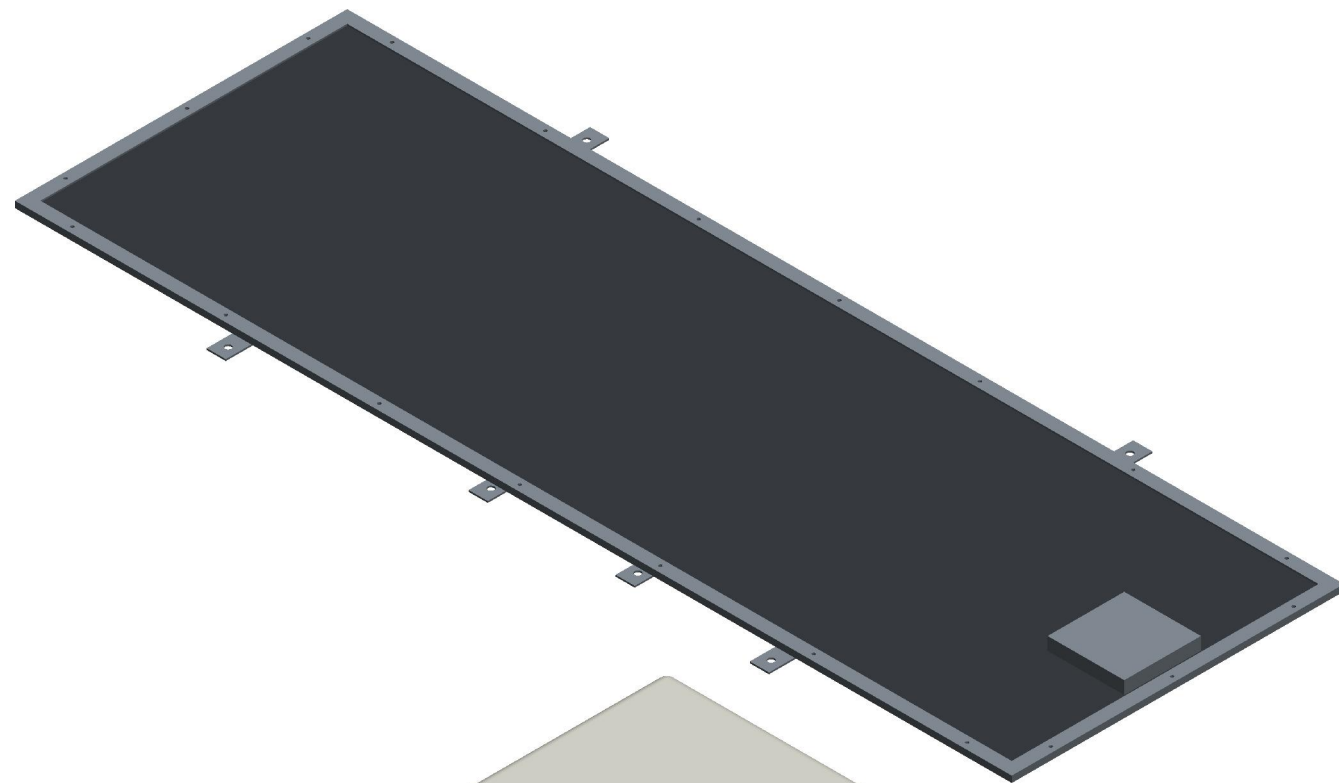

| | | | | | |
|---------------------------------|------|-----------|---------------------|----------------|-------|
| GENERAL TOLERANCES UNLESS NOTED | | | N.S.S.P.C.M. | | |
| .XXX | .XX | ANGLES | | | |
| 0.050 | 0.10 | 0.50 | MODEL | | |
| DRAWN | | DATE | MASTER | | |
| D.E.LUCAS | | May-10-12 | | | |
| CHECKED | | DATE | SIZE | DRAWING NAME | |
| | | | B | MASTER_DRAWING | |
| APPROVED | | DATE | SCALE | MATERIAL | SHEET |
| | | | 0.125 | N / A | 12/12 |