

**Concept 1: Two Controllers with Dedicated COM Ports**

**Level 0: Plant Robot Input/Output**

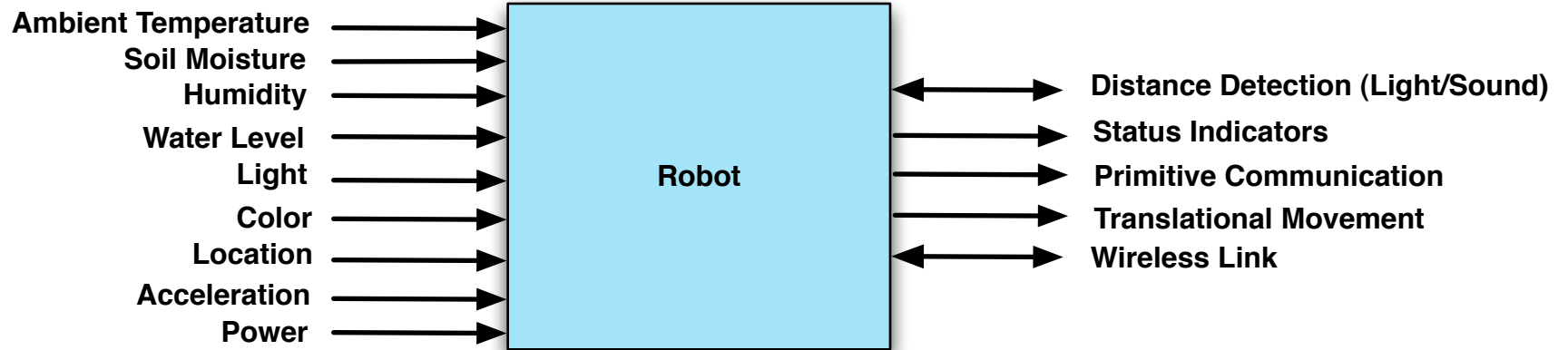

**Level 1: Platform Architecture Overview**

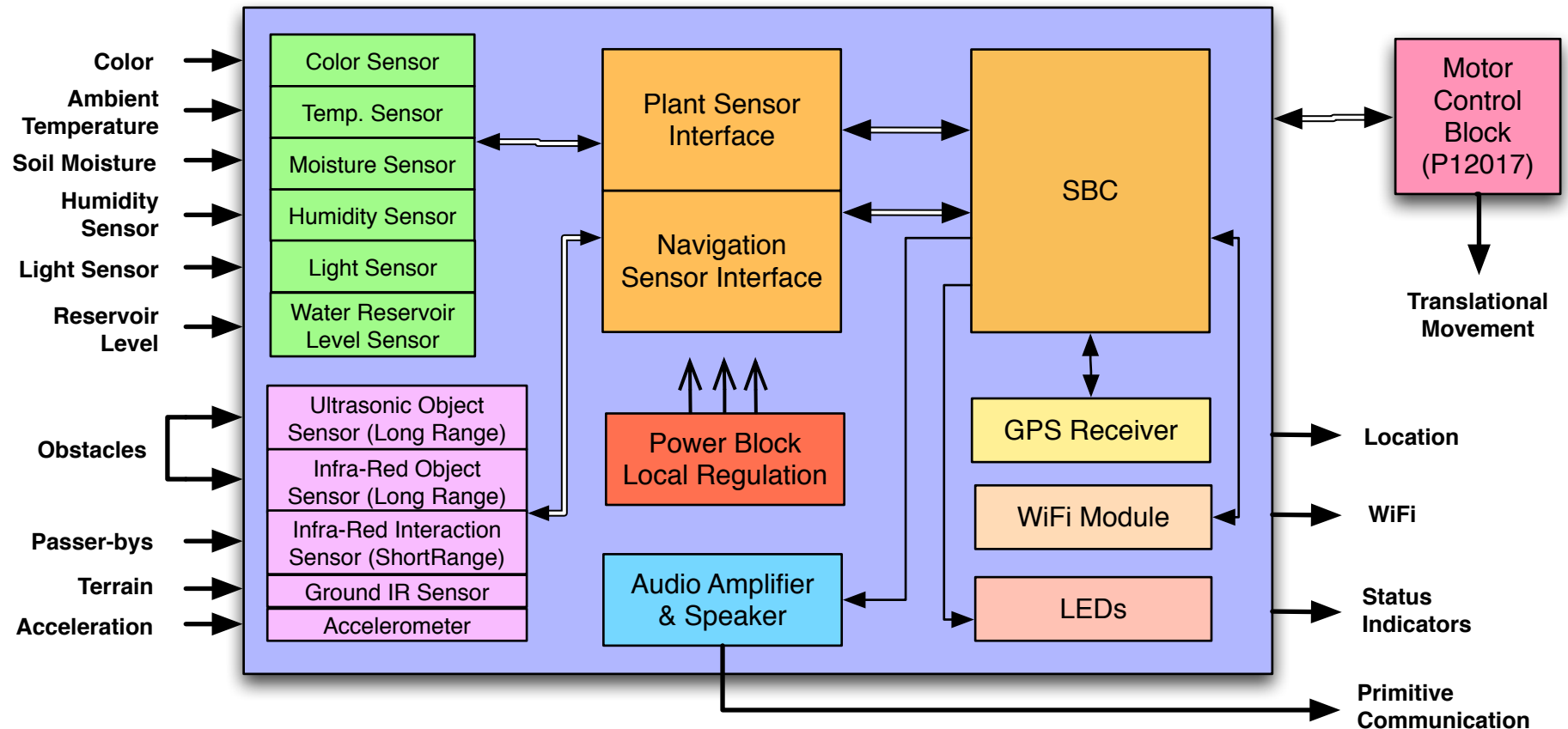

**Concept 2: One main controller  
interfacing to all sensors**

**Level 0: Plant Robot Input/Output**

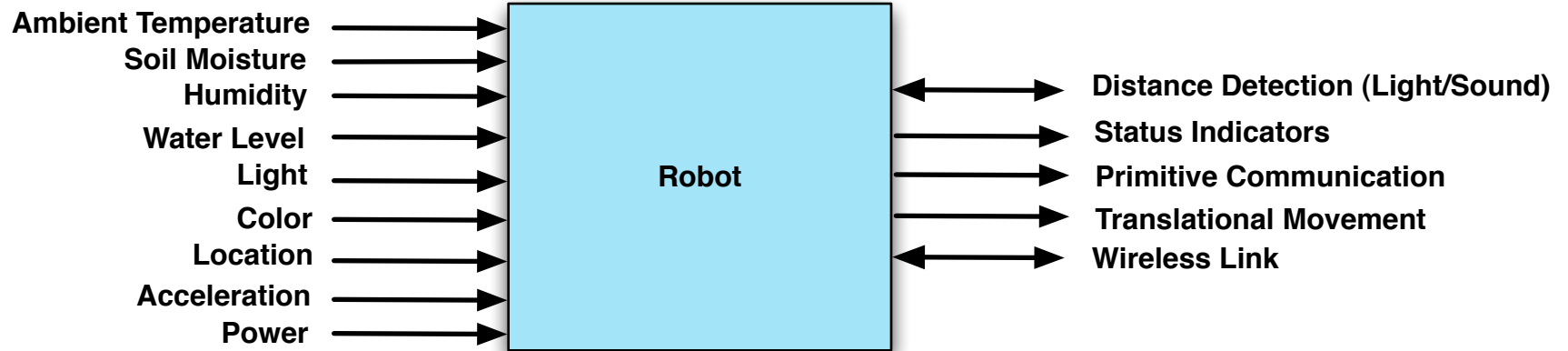

**Level 1: Platform Architecture Overview**

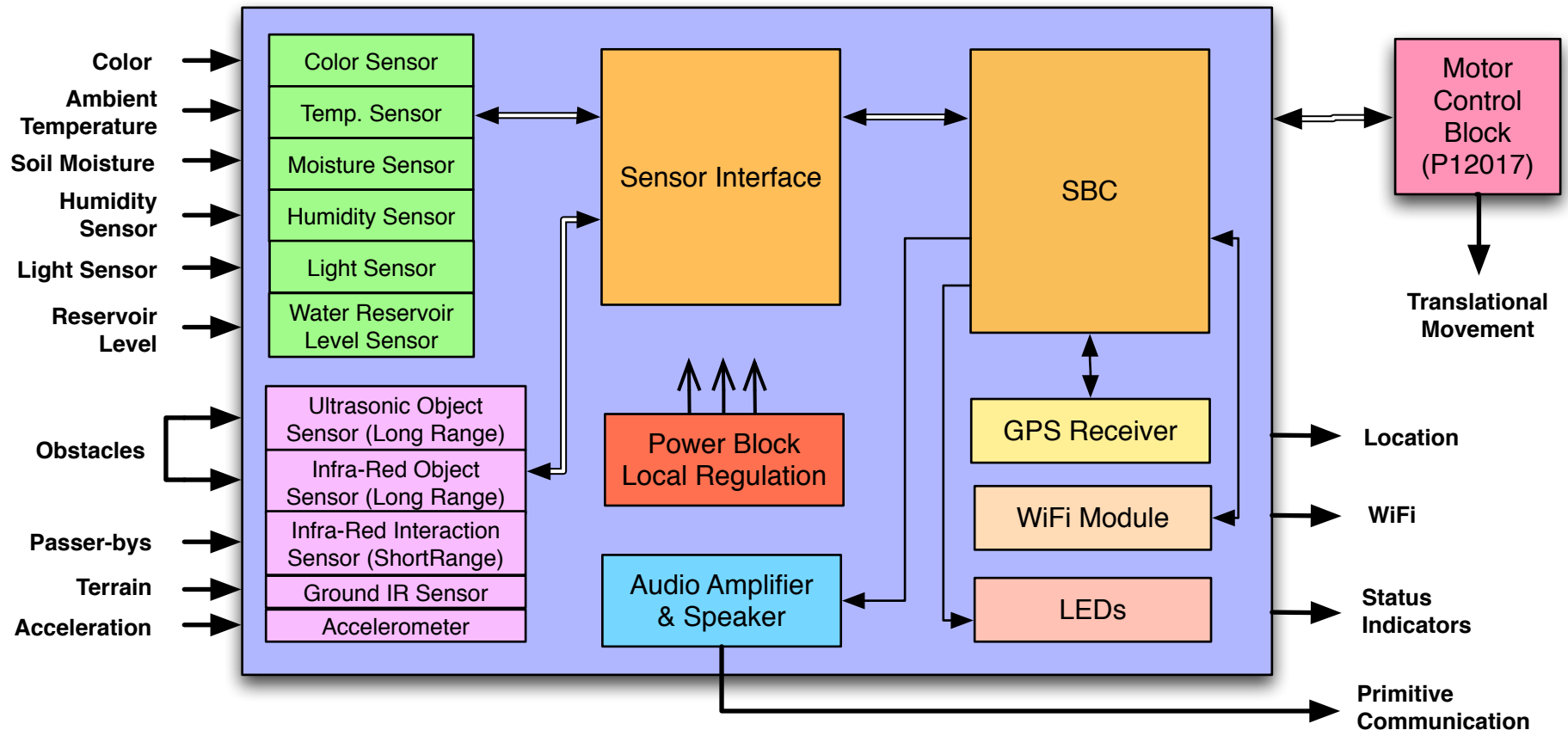

### Concept 3: Two Controllers with Master-Slave Communication

Level 0: Plant Robot Input/Output

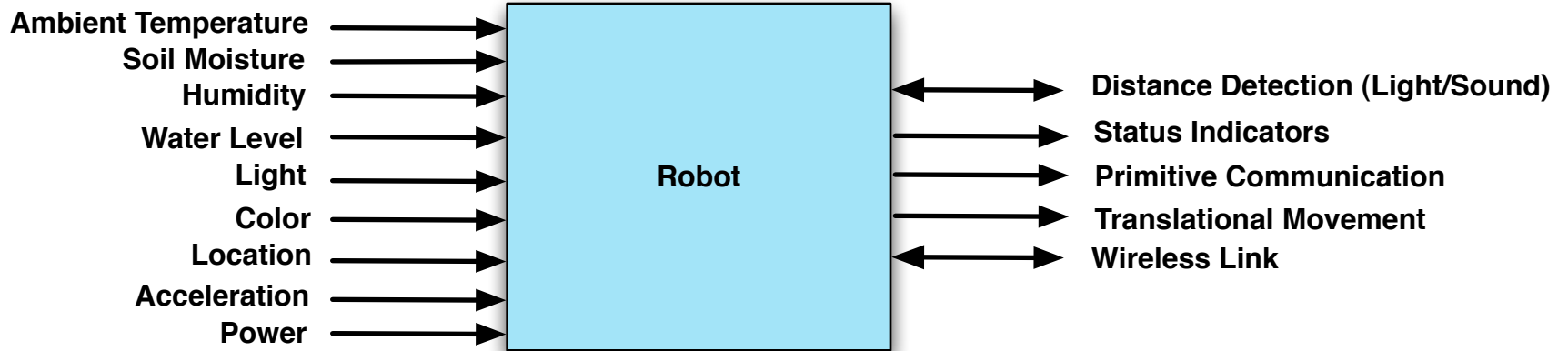

Level 1: Platform Architecture Overview

