

8 7 6 5 4 3 2 1

D
C
B
A

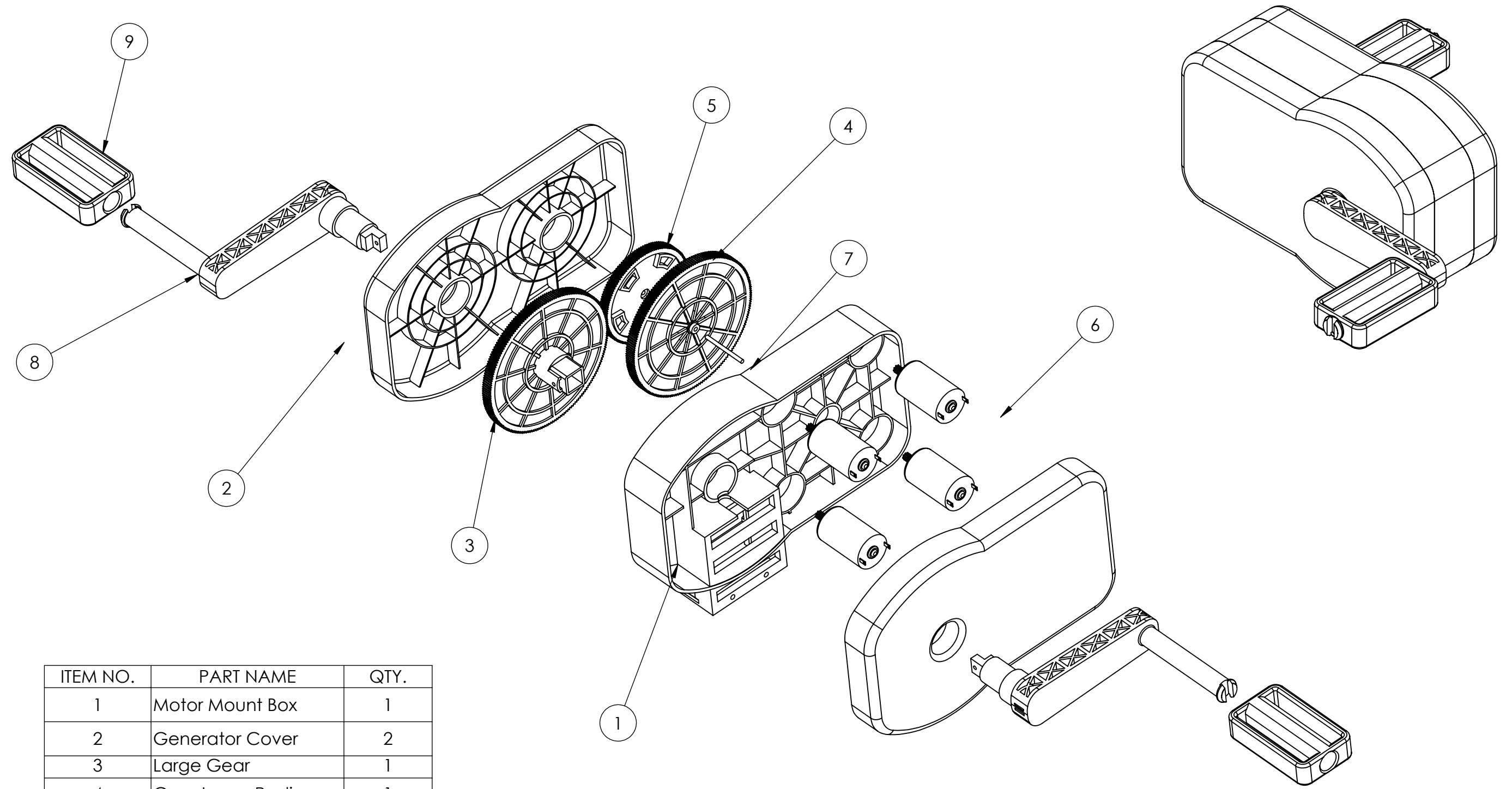

ITEM NO.	PART NAME	QTY.
1	Motor Mount Box	1
2	Generator Cover	2
3	Large Gear	1
4	Gear Large Radius	1
5	Gear Small Radius	1
6	Motor	4
7	Steel Axle	1
8	Crank Arm	2
9	Crank Pedal	2

PROPRIETARY AND CONFIDENTIAL
 THE INFORMATION CONTAINED IN THIS DRAWING IS THE SOLE PROPERTY OF <INSERT COMPANY NAME HERE>. ANY REPRODUCTION IN PART OR AS A WHOLE WITHOUT THE WRITTEN PERMISSION OF <INSERT COMPANY NAME HERE> IS PROHIBITED.

		UNLESS OTHERWISE SPECIFIED:		NAME	DATE
		DIMENSIONS ARE IN INCHES		DRAWN	NJH 11/6/12
		TOLERANCES:		CHECKED	NJH 11/6/12
		FRACTIONAL ±		ENG APPR.	
		ANGULAR: MACH ± BEND ±		MFG APPR.	
		TWO PLACE DECIMAL ±		Q.A.	
		THREE PLACE DECIMAL ±		COMMENTS:	
		INTERPRET GEOMETRIC TOLERANCING PER: N/A			
		MATERIAL: N/A			
		FINISH: N/A			
NEXT ASSY	USED ON				
APPLICATION		DO NOT SCALE DRAWING			
TITLE: GENERATOR HOUSING					
SIZE	DWG. NO.			REV	
B	ASSEMBLY				
SCALE: 1:16		WEIGHT: N/A		SHEET 1 OF 1	

8 7 6 5 4 3 2 1

ITEM NO.	PART NAME	QTY.
1	Motor Mount Box	1
2	Generator Cover	2
3	Large Gear	1
4	Gear Large Radius	1
5	Gear Small Radius	1
6	Motor	4
7	Stl Axle	1
8	Crank Arm	2
9	Crank Pedal	2

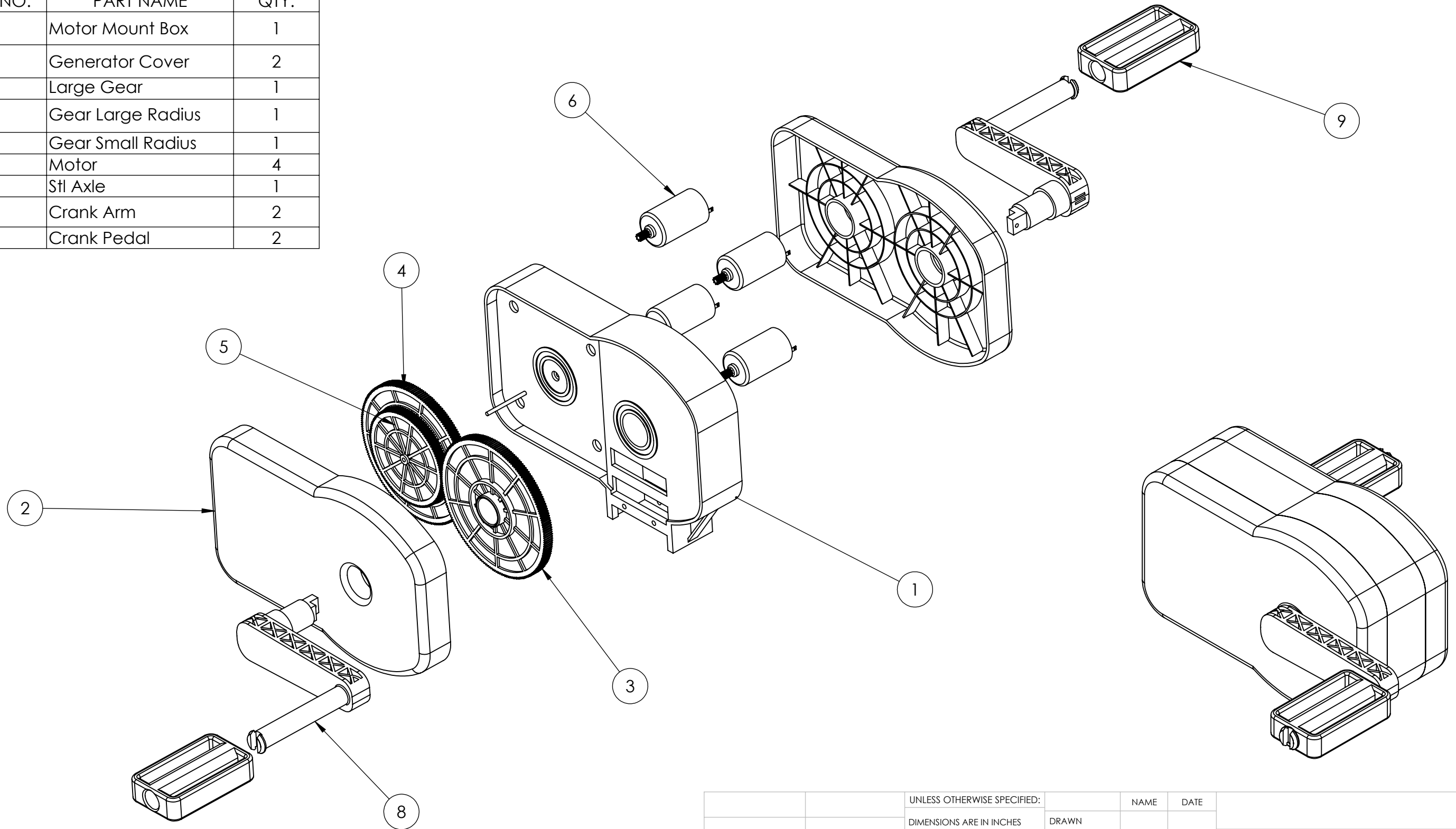

PROPRIETARY AND CONFIDENTIAL
 THE INFORMATION CONTAINED IN THIS DRAWING IS THE SOLE PROPERTY OF <INSERT COMPANY NAME HERE>. ANY REPRODUCTION IN PART OR AS A WHOLE WITHOUT THE WRITTEN PERMISSION OF <INSERT COMPANY NAME HERE> IS PROHIBITED.

		UNLESS OTHERWISE SPECIFIED:		NAME	DATE
		DIMENSIONS ARE IN INCHES		DRAWN	
		TOLERANCES:		CHECKED	
		FRACTIONAL ±		ENG APPR.	
		ANGULAR: MACH ± BEND ±		MFG APPR.	
		TWO PLACE DECIMAL ±		Q.A.	
		THREE PLACE DECIMAL ±		COMMENTS:	
		INTERPRET GEOMETRIC TOLERANCING PER:			
		MATERIAL			
		FINISH			
NEXT ASSY	USED ON				
APPLICATION		DO NOT SCALE DRAWING			
				TITLE:	
		SIZE	DWG. NO.	REV	
		(Proposed) BHousing Assembly V			
SCALE: 1:16			WEIGHT:	SHEET 1 OF 1	

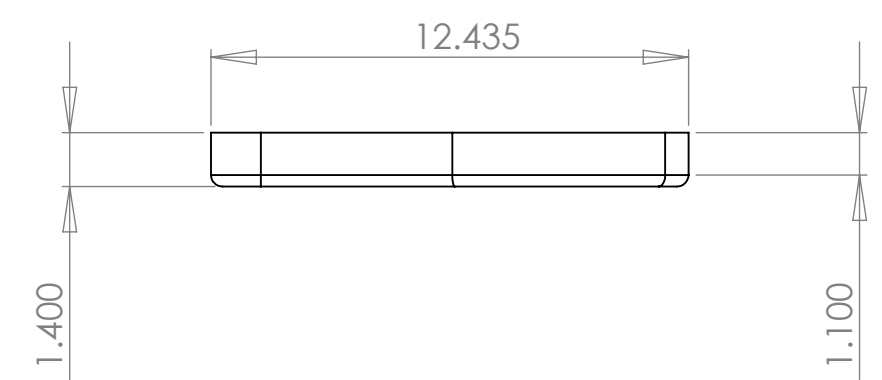
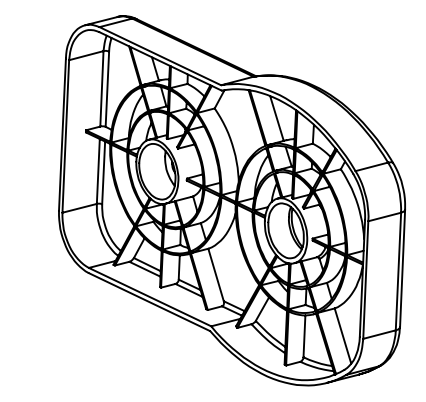
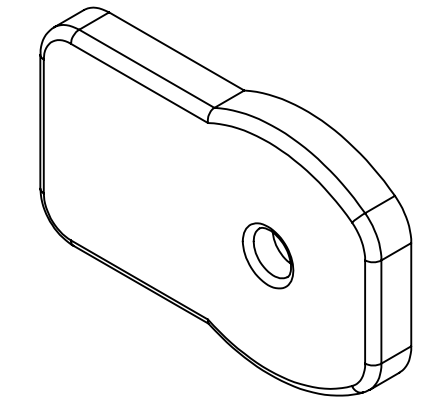
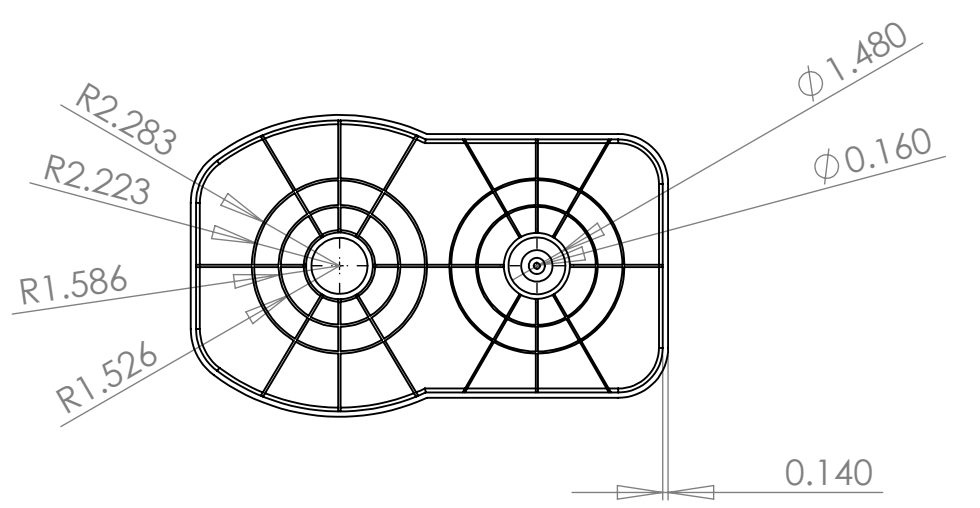
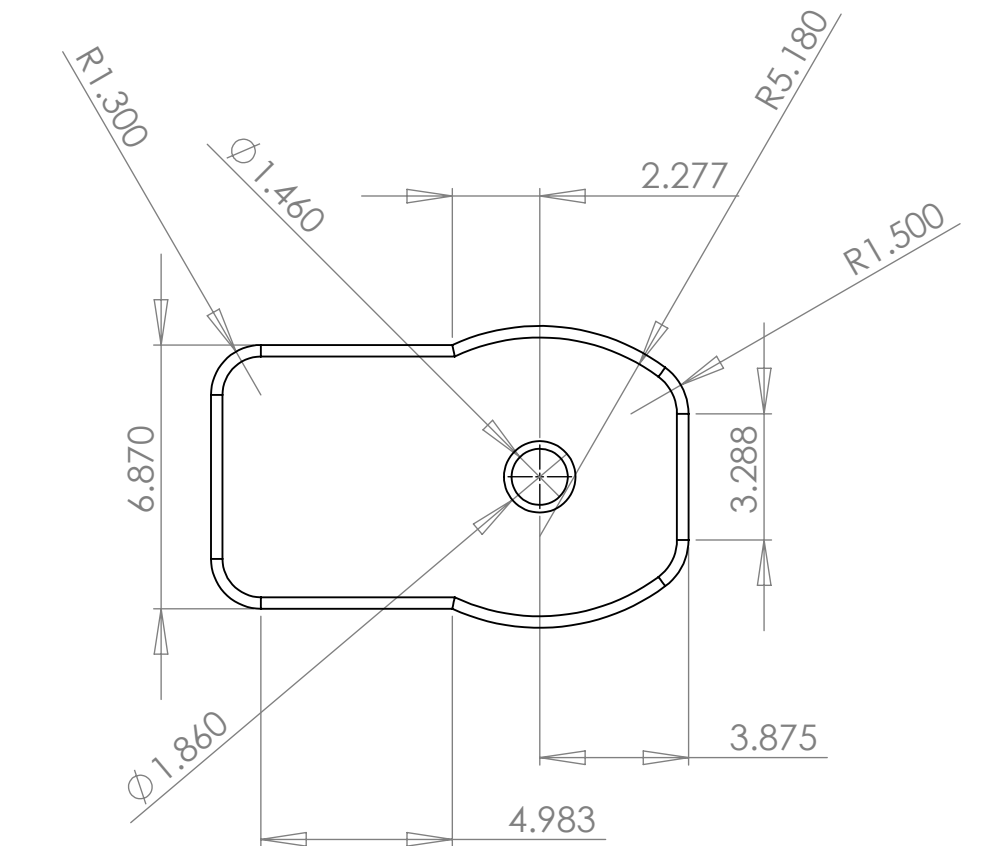

PROPRIETARY AND CONFIDENTIAL
 THE INFORMATION CONTAINED IN THIS DRAWING IS THE SOLE PROPERTY OF <INSERT COMPANY NAME HERE>. ANY REPRODUCTION IN PART OR AS A WHOLE WITHOUT THE WRITTEN PERMISSION OF <INSERT COMPANY NAME HERE> IS PROHIBITED.

		UNLESS OTHERWISE SPECIFIED:		NAME	DATE
		DIMENSIONS ARE IN INCHES		DRAWN	NJH 11/6/12
		TOLERANCES:		CHECKED	NJH 11/6/12
		FRACTIONAL ±		ENG APPR.	
		ANGULAR: MACH ± BEND ±		MFG APPR.	
		TWO PLACE DECIMAL ±		Q.A.	
		THREE PLACE DECIMAL ±0.001		COMMENTS:	
		INTERPRET GEOMETRIC TOLERANCING PER: N/A			
		MATERIAL			
		HARBEC PLASTIC			
		FINISH:			
		N/A			
NEXT ASSY	USED ON				
APPLICATION		DO NOT SCALE DRAWING			
TITLE:					
GENERATOR HOUSING ASSEMBLY					
SIZE	DWG. NO.			REV	
B	GENERATOR COVER				
SCALE: 1:5	WEIGHT: 362 g	SHEET 1 OF 1			

8 7 6 5 4 3 2 1

D
C
B
A

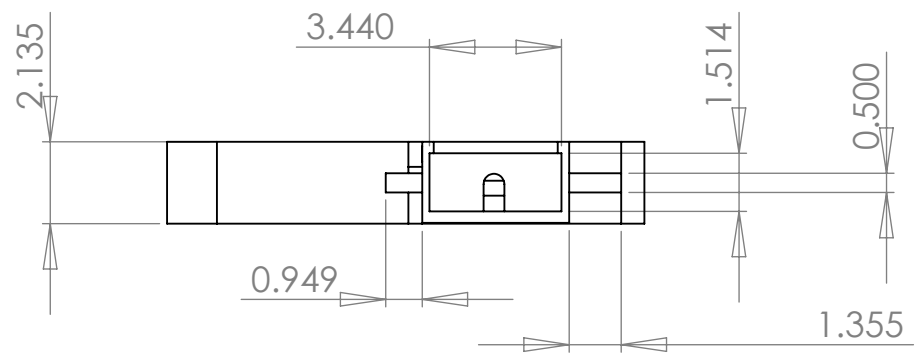
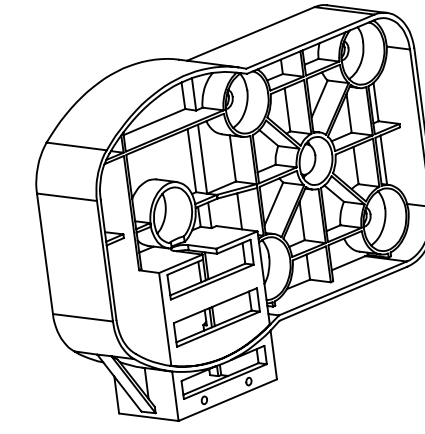
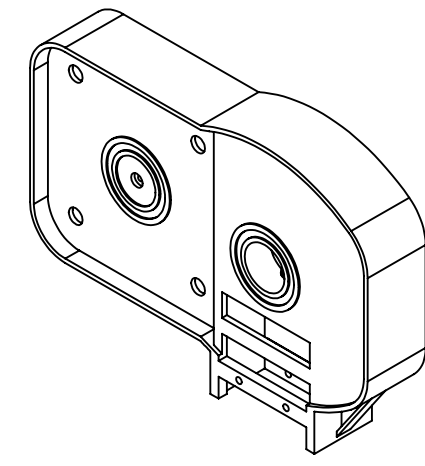
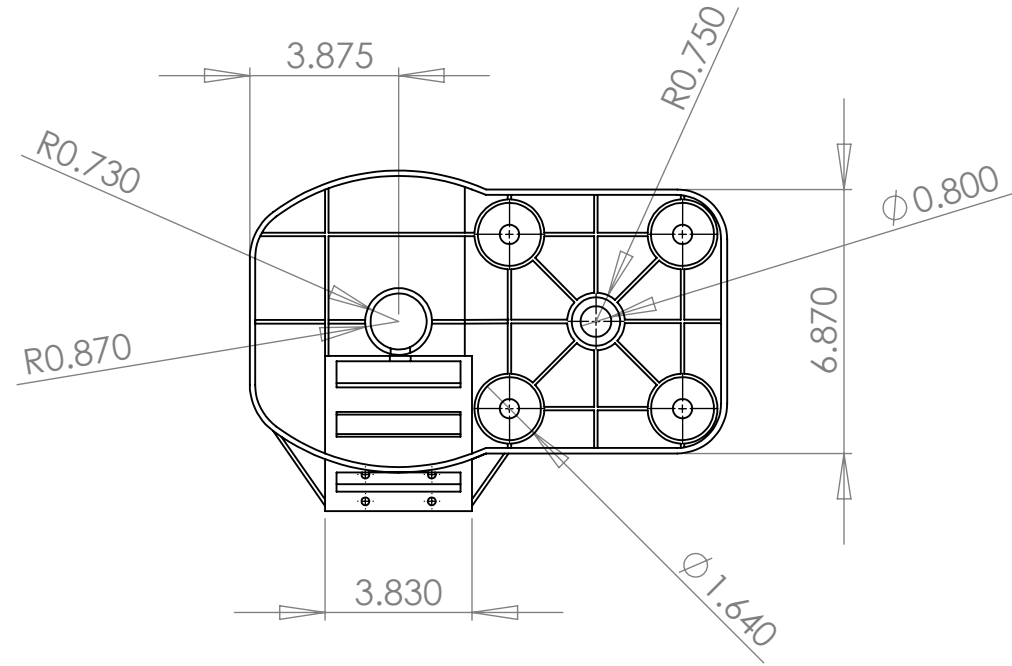
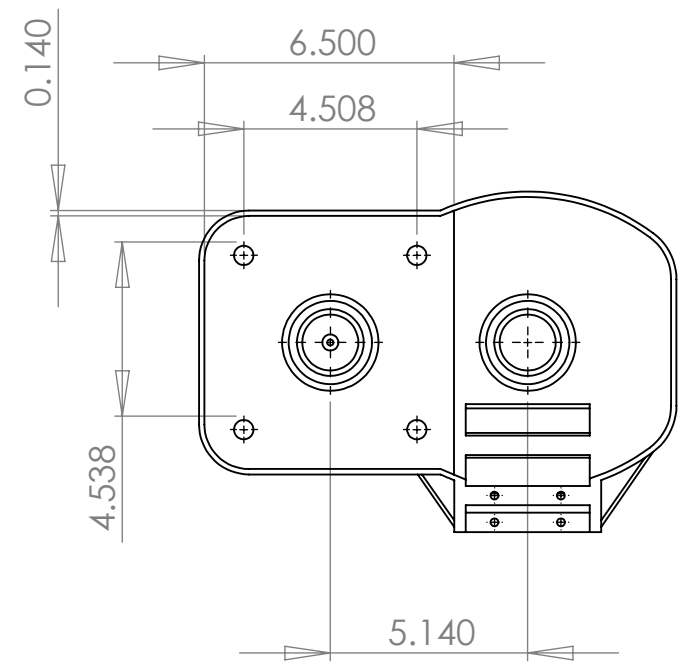

PROPRIETARY AND CONFIDENTIAL
THE INFORMATION CONTAINED IN THIS DRAWING IS THE SOLE PROPERTY OF <INSERT COMPANY NAME HERE>. ANY REPRODUCTION IN PART OR AS A WHOLE WITHOUT THE WRITTEN PERMISSION OF <INSERT COMPANY NAME HERE> IS PROHIBITED.

		UNLESS OTHERWISE SPECIFIED:		NAME	DATE	TITLE: GENERATOR HOUSING ASSEMBLY	
		DIMENSIONS ARE IN INCHES		DRAWN	NJH		11/6/12
		TOLERANCES:		CHECKED	NJH		11/6/12
		FRACTIONAL ±		ENG APPR.			
		ANGULAR: MACH ± BEND ±		MFG APPR.			
		TWO PLACE DECIMAL ±		Q.A.			
		THREE PLACE DECIMAL ±0.001		COMMENTS:			
		INTERPRET GEOMETRIC TOLERANCING PER: N/A					
		MATERIAL: HARBEC PLASTIC				SIZE B	
NEXT ASSY		USED ON				DWG. NO. MOTOR MOUNT BOX	
						REV	
APPLICATION		DO NOT SCALE DRAWING				SCALE: 1:5 WEIGHT: 1000g SHEET 1 OF 1	

8 7 6 5 4 3 2 1

8 7 6 5 4 3 2 1

D
C
B
A

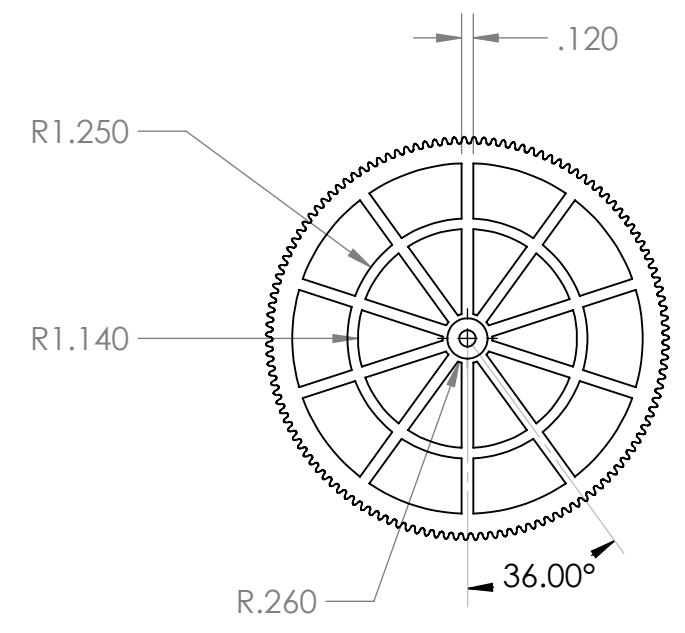
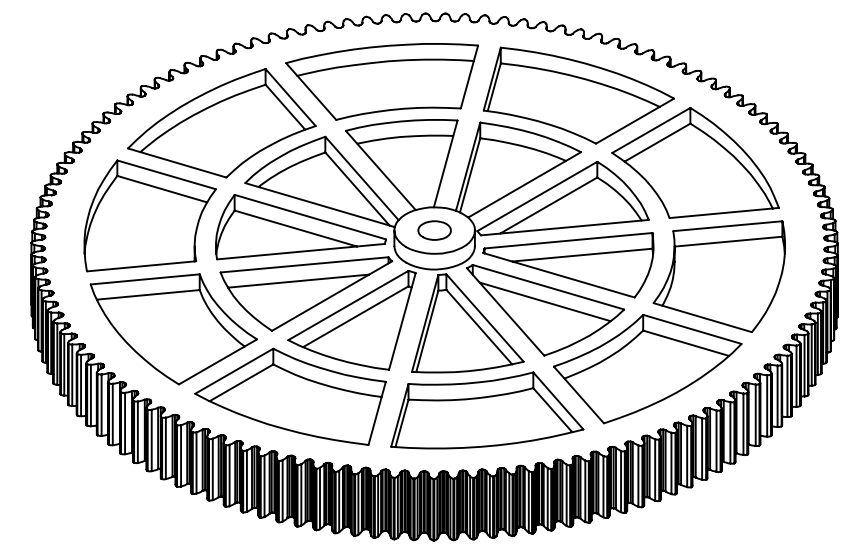
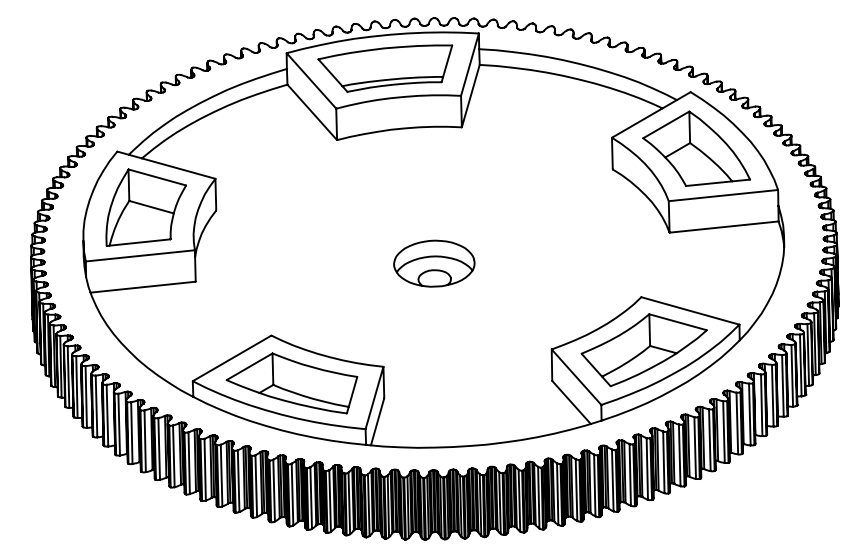
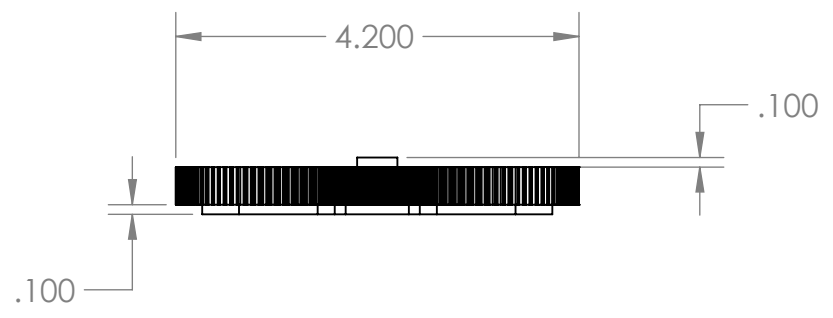
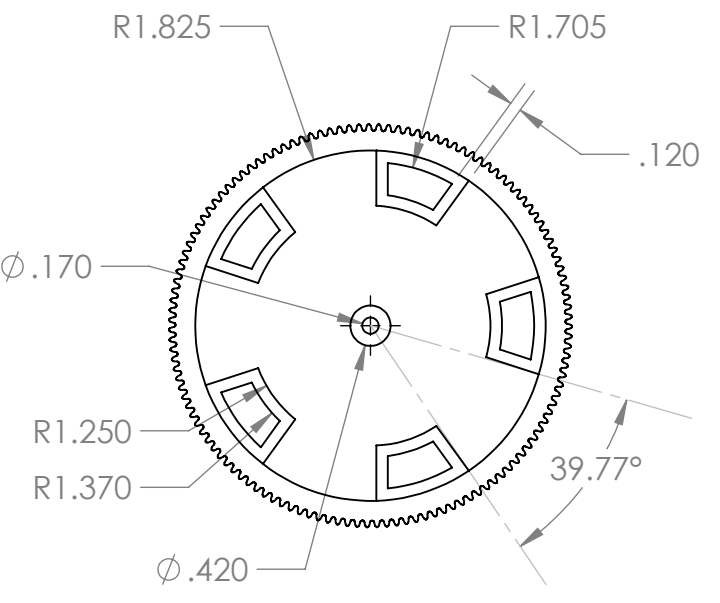

PROPRIETARY AND CONFIDENTIAL
 THE INFORMATION CONTAINED IN THIS DRAWING IS THE SOLE PROPERTY OF <INSERT COMPANY NAME HERE>. ANY REPRODUCTION IN PART OR AS A WHOLE WITHOUT THE WRITTEN PERMISSION OF <INSERT COMPANY NAME HERE> IS PROHIBITED.

		UNLESS OTHERWISE SPECIFIED:		NAME	DATE	TITLE: GENERATOR HOUSING ASSEMBLY	
		DIMENSIONS ARE IN INCHES		DRAWN	NJH		11/6/12
		TOLERANCES:		CHECKED	NJH		11/6/12
		FRACTIONAL ±		ENG APPR.			
		ANGULAR: MACH ±		MFG APPR.			
		BEND ±		Q.A.			
		TWO PLACE DECIMAL ±		COMMENTS:			
		THREE PLACE DECIMAL ± 0.001					
		INTERPRET GEOMETRIC TOLERANCING PER: N/A					
		MATERIAL: HARBEC PLASTIC				SIZE B	
		FINISH: N/A				DWG. NO. GEAR SMALL RADIUS	
NEXT ASSY	USED ON					REV	
APPLICATION		DO NOT SCALE DRAWING				SCALE: 1:1	
						WEIGHT: 112 g	
						SHEET 1 OF 1	

8 7 6 5 4 3 2 1

8 7 6 5 4 3 2 1

D
C
B
A

D
C
B
A

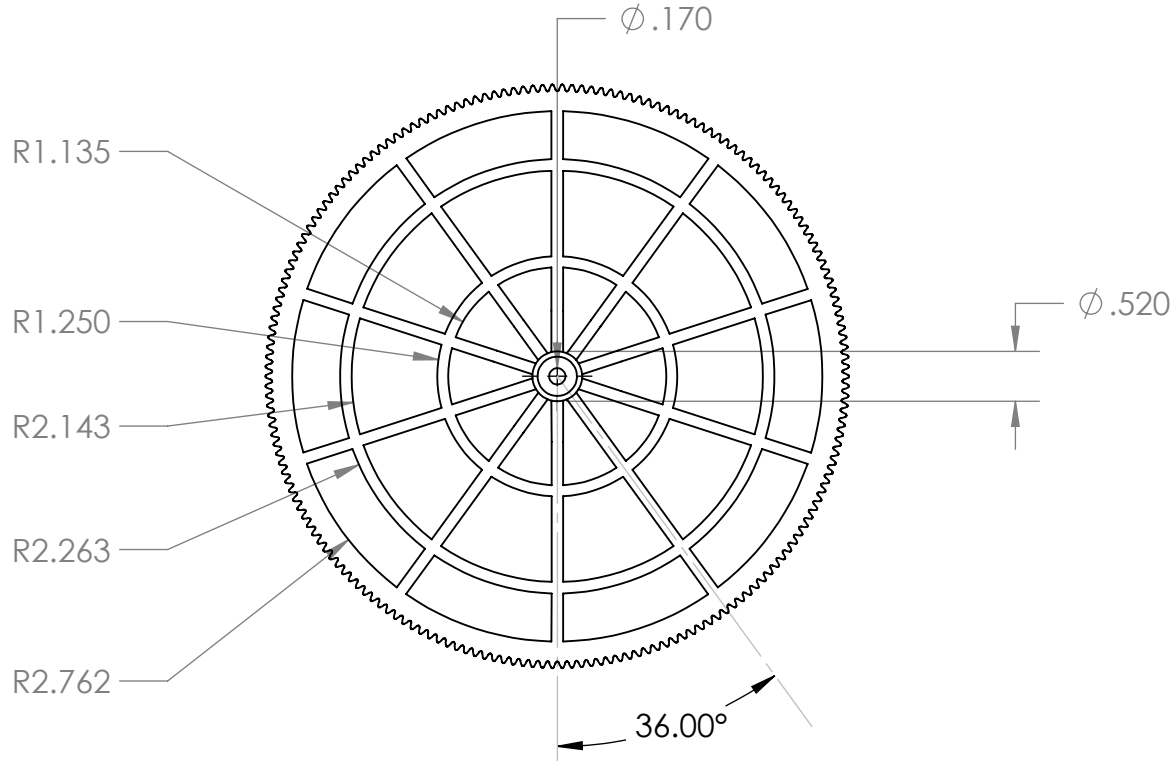
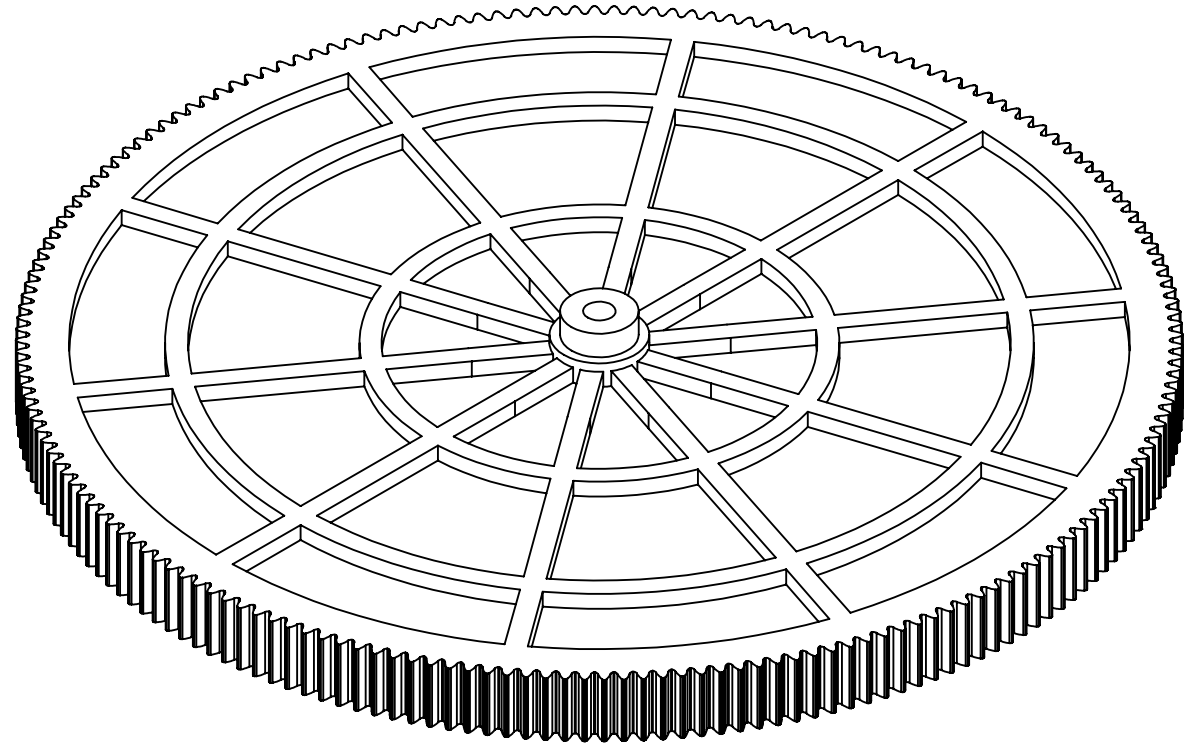
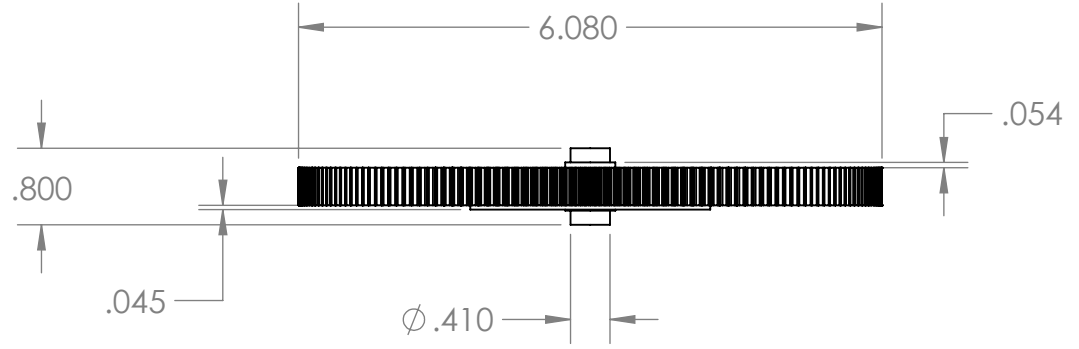

PROPRIETARY AND CONFIDENTIAL
 THE INFORMATION CONTAINED IN THIS DRAWING IS THE SOLE PROPERTY OF <INSERT COMPANY NAME HERE>. ANY REPRODUCTION IN PART OR AS A WHOLE WITHOUT THE WRITTEN PERMISSION OF <INSERT COMPANY NAME HERE> IS PROHIBITED.

		UNLESS OTHERWISE SPECIFIED:		NAME	DATE	TITLE: GENERATOR HOUSING ASSEMBLY	
		DIMENSIONS ARE IN INCHES		DRAWN	NJH		11/7/12
		TOLERANCES:		CHECKED	NJH		11/7/12
		FRACTIONAL ±		ENG APPR.			
		ANGULAR: MACH ± BEND ±		MFG APPR.			
		TWO PLACE DECIMAL ±		Q.A.			
		THREE PLACE DECIMAL ±0.001		COMMENTS:			
		INTERPRET GEOMETRIC TOLERANCING PER: N/A					
		MATERIAL: HARBEC PLASTIC					
		FINISH: N/A					
NEXT ASSY	USED ON						
APPLICATION		DO NOT SCALE DRAWING					
SIZE	DWG. NO.	REV					
B	GEAR LARGE RADIUS						
SCALE: 1:2	WEIGHT: 232 G	SHEET 1 OF 1					

8 7 6 5 4 3 2 1

8 7 6 5 4 3 2 1

D

D

C

C

B

B

A

A

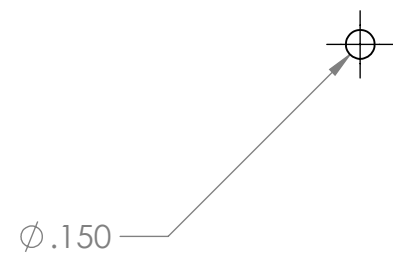
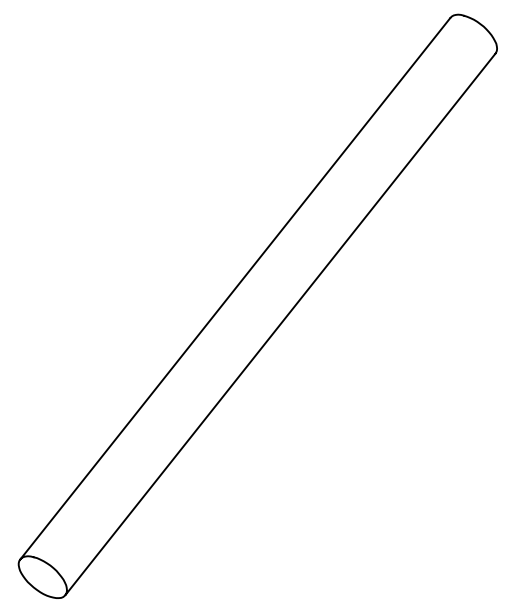
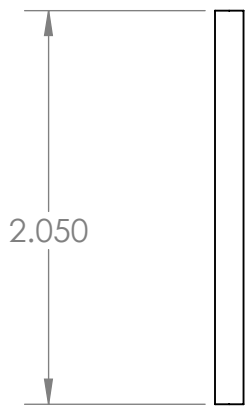

PROPRIETARY AND CONFIDENTIAL
 THE INFORMATION CONTAINED IN THIS DRAWING IS THE SOLE PROPERTY OF <INSERT COMPANY NAME HERE>. ANY REPRODUCTION IN PART OR AS A WHOLE WITHOUT THE WRITTEN PERMISSION OF <INSERT COMPANY NAME HERE> IS PROHIBITED.

		UNLESS OTHERWISE SPECIFIED:		NAME	DATE	TITLE: <h3 style="text-align: center;">GENERATOR HOUSING ASSEMBLY</h3>
		DIMENSIONS ARE IN INCHES	DRAWN	NJH	11/7/12	
		TOLERANCES:	CHECKED	NJH	11/7/12	
		FRACTIONAL ±	ENG APPR.			
		ANGULAR: MACH ± BEND ±	MFG APPR.			
		TWO PLACE DECIMAL ±	Q.A.			SIZE B DWG. NO. STEEL AXLE REV SCALE: 2:1 WEIGHT: 8 g SHEET 1 OF 1
		THREE PLACE DECIMAL ± 0.001	COMMENTS:			
		INTERPRET GEOMETRIC TOLERANCING PER: N/A				
		MATERIAL				
		STEEL				
		FINISH:				
		N/A				
NEXT ASSY	USED ON					
APPLICATION		DO NOT SCALE DRAWING				

8 7 6 5 4 3 2 1

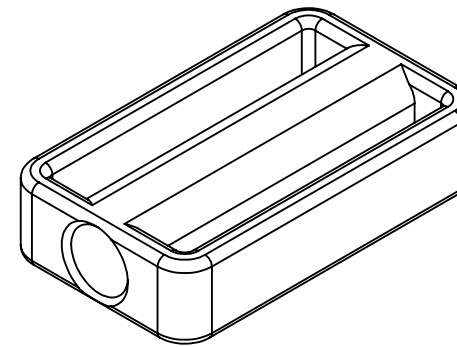
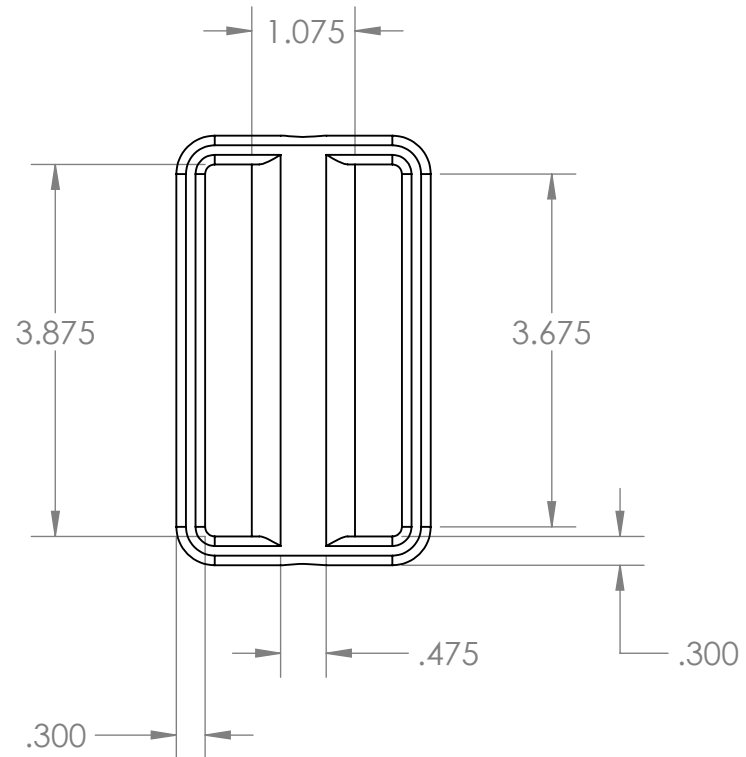
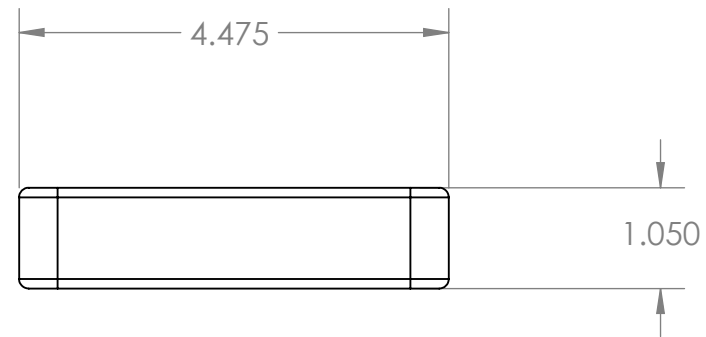
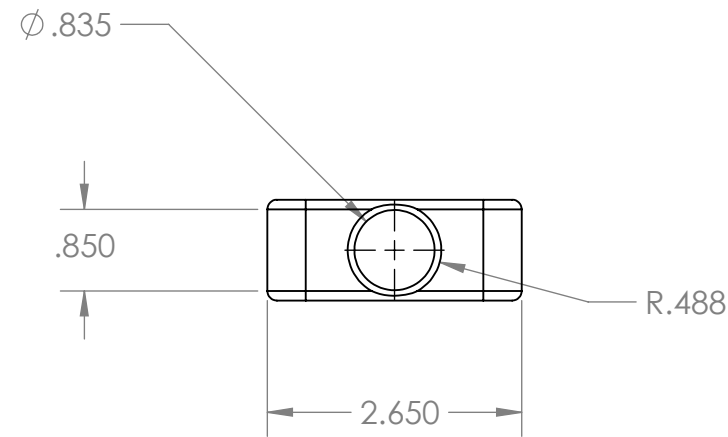

PROPRIETARY AND CONFIDENTIAL
 THE INFORMATION CONTAINED IN THIS DRAWING IS THE SOLE PROPERTY OF <INSERT COMPANY NAME HERE>. ANY REPRODUCTION IN PART OR AS A WHOLE WITHOUT THE WRITTEN PERMISSION OF <INSERT COMPANY NAME HERE> IS PROHIBITED.

		UNLESS OTHERWISE SPECIFIED:		NAME	DATE
		DIMENSIONS ARE IN INCHES		DRAWN	NJH 11/7/12
		TOLERANCES:		CHECKED	NJH 11/7/12
		FRACTIONAL \pm		ENG APPR.	
		ANGULAR: MACH \pm BEND \pm		MFG APPR.	
		TWO PLACE DECIMAL \pm		Q.A.	
		THREE PLACE DECIMAL ± 0.001		COMMENTS:	
		INTERPRET GEOMETRIC TOLERANCING PER: N/A			
		MATERIAL: HARBEC PLASTIC			
NEXT ASSY	USED ON	FINISH: N/A			
APPLICATION		DO NOT SCALE DRAWING			
TITLE:			Generator Housing Assembly		
SIZE	DWG. NO.	REV			
B	Pedal				
SCALE: 1:1	WEIGHT: 168 g	SHEET 1 OF 1			

8 7 6 5 4 3 2 1

D
C
B
A

D
C
B
A

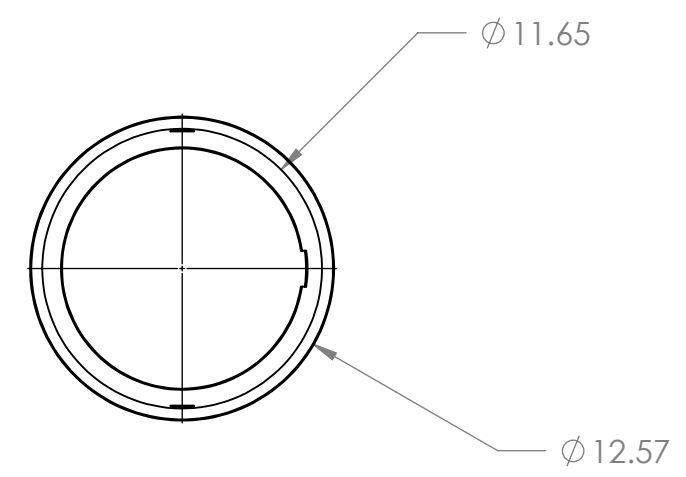
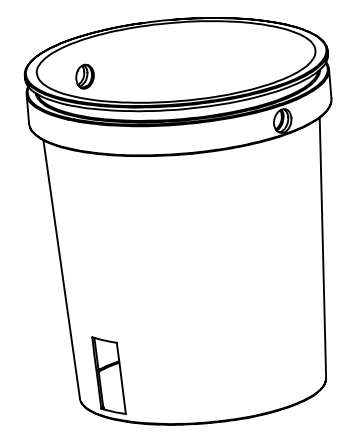
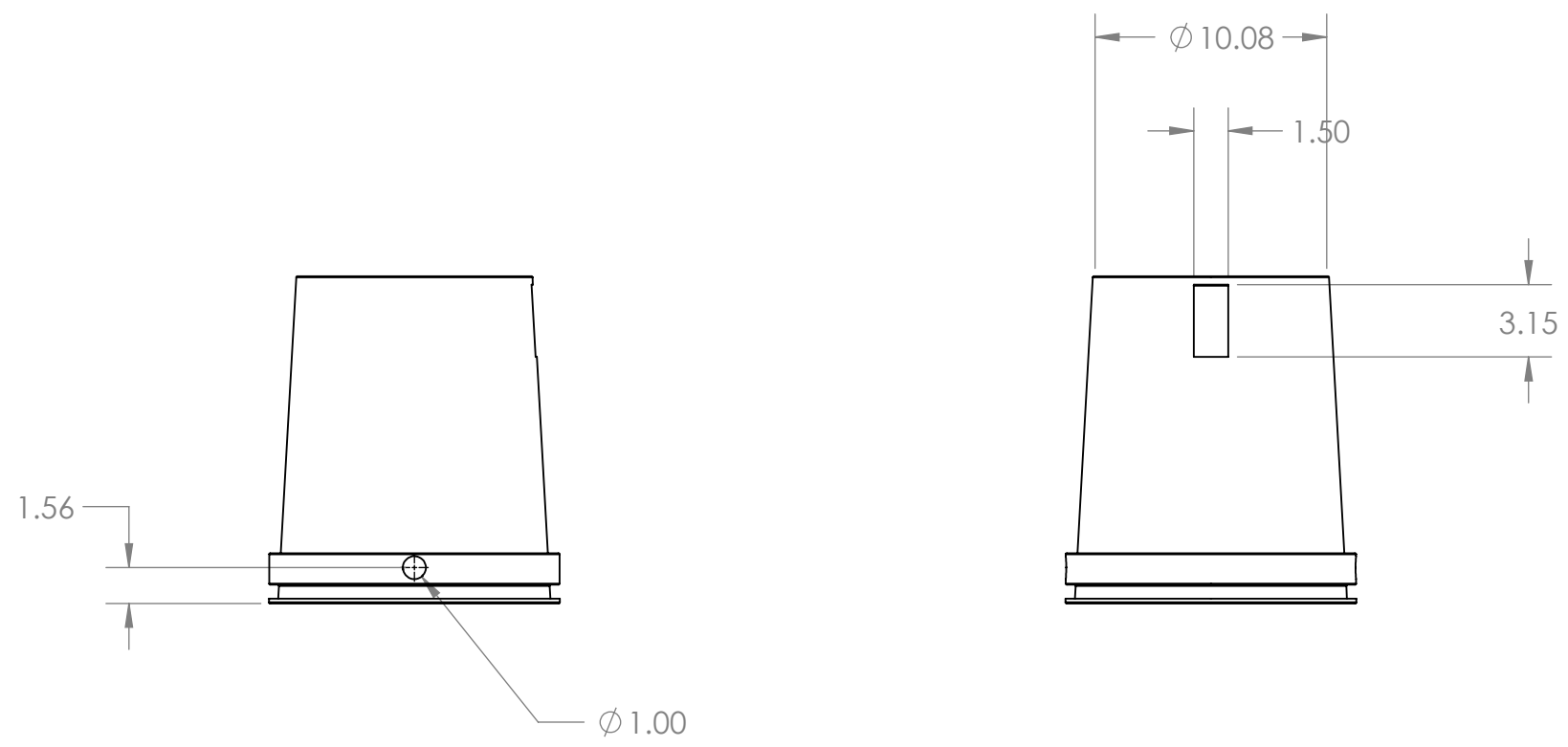

PROPRIETARY AND CONFIDENTIAL
 THE INFORMATION CONTAINED IN THIS DRAWING IS THE SOLE PROPERTY OF <INSERT COMPANY NAME HERE>. ANY REPRODUCTION IN PART OR AS A WHOLE WITHOUT THE WRITTEN PERMISSION OF <INSERT COMPANY NAME HERE> IS PROHIBITED.

		UNLESS OTHERWISE SPECIFIED:		NAME	DATE	TITLE: SEATING ASSEMBLY		
		DIMENSIONS ARE IN INCHES		DRAWN	NJH			11/7/12
		TOLERANCES:		CHECKED	NJH			11/7/12
		FRACTIONAL ±		ENG APPR.				
		ANGULAR: MACH ± BEND ±		MFG APPR.				
		TWO PLACE DECIMAL ± 0.01		Q.A.			SIZE DWG. NO. REV	
		THREE PLACE DECIMAL ±		COMMENTS:				
		INTERPRET GEOMETRIC TOLERANCING PER: N/A						
		MATERIAL: LOWES PLASTIC (POLYPROPYLENE)						
NEXT ASSY		USED ON						
		FINISH: N/A						
APPLICATION		DO NOT SCALE DRAWING				SCALE: 1:8 WEIGHT: 2000g SHEET 1 OF 1		

8 7 6 5 4 3 2 1

8 7 6 5 4 3 2 1

D
C
B
A

D
C
B
A

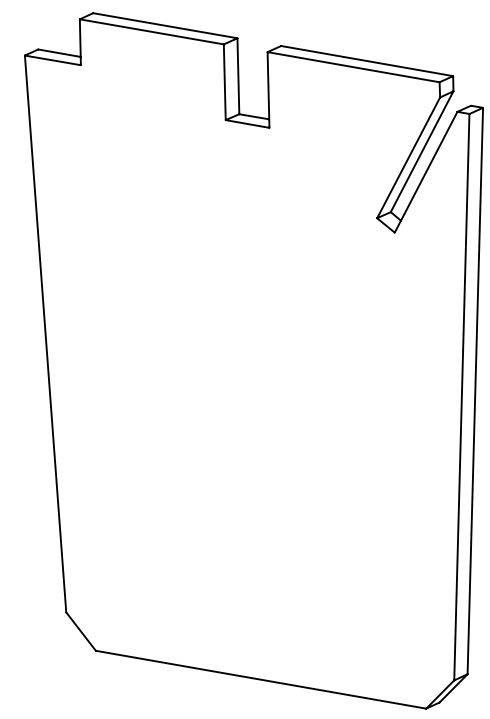
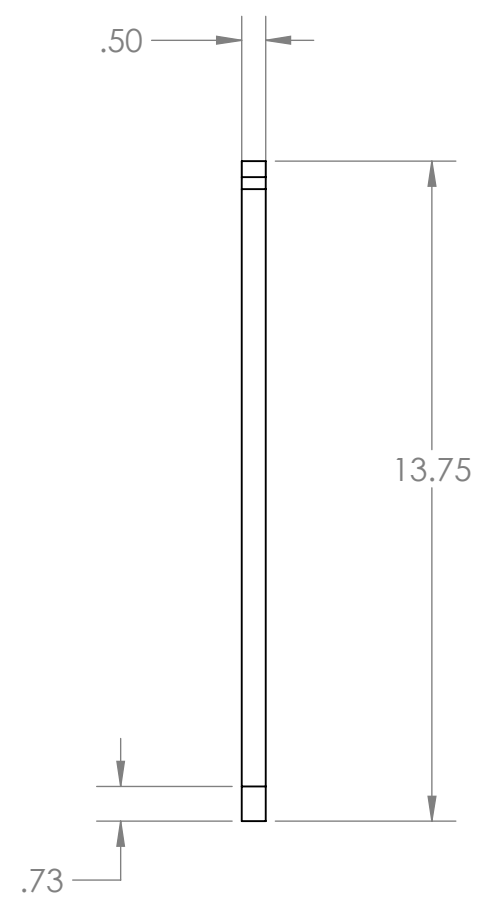
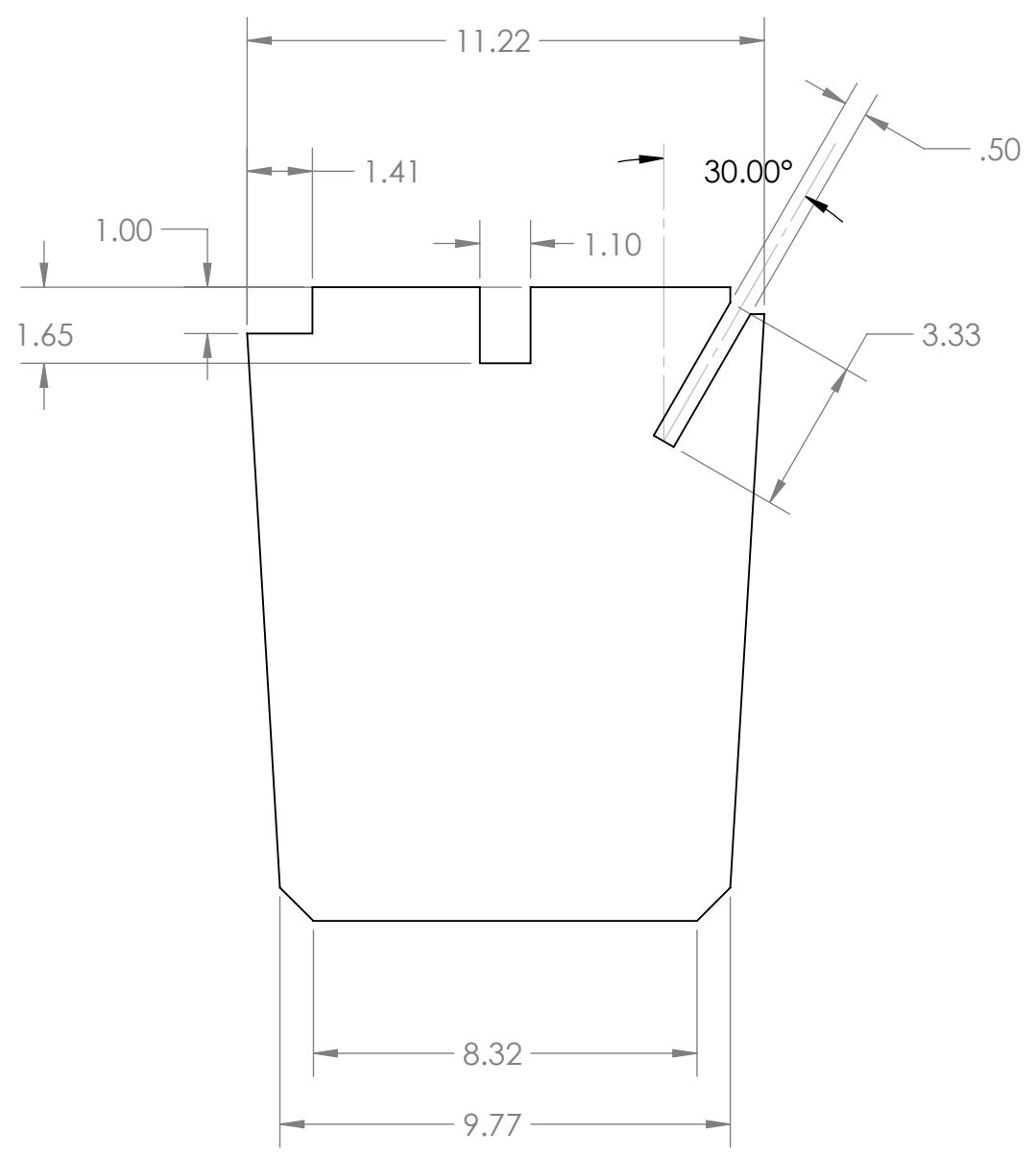

PROPRIETARY AND CONFIDENTIAL
 THE INFORMATION CONTAINED IN THIS DRAWING IS THE SOLE PROPERTY OF <INSERT COMPANY NAME HERE>. ANY REPRODUCTION IN PART OR AS A WHOLE WITHOUT THE WRITTEN PERMISSION OF <INSERT COMPANY NAME HERE> IS PROHIBITED.

		UNLESS OTHERWISE SPECIFIED:		NAME	DATE	TITLE: SEATING ASSEMBLY
		DIMENSIONS ARE IN INCHES		DRAWN	NJH 11/7/12	
		TOLERANCES:		CHECKED	NJH 11/7/12	
		FRACTIONAL ±		ENG APPR.		
		ANGULAR: MACH ± BEND ±		MFG APPR.		
		TWO PLACE DECIMAL ±0.01		Q.A.		SIZE DWG. NO. REV B PLYWOOD INSERT
		THREE PLACE DECIMAL ±		COMMENTS:		
		INTERPRET GEOMETRIC TOLERANCING PER: N/A				SCALE: 1:4 WEIGHT: 680 g SHEET 1 OF 1
		MATERIAL: PLYWOOD - PINE				
NEXT ASSY	USED ON	FINISH: N/A				
APPLICATION		DO NOT SCALE DRAWING				

8 7 6 5 4 3 2 1

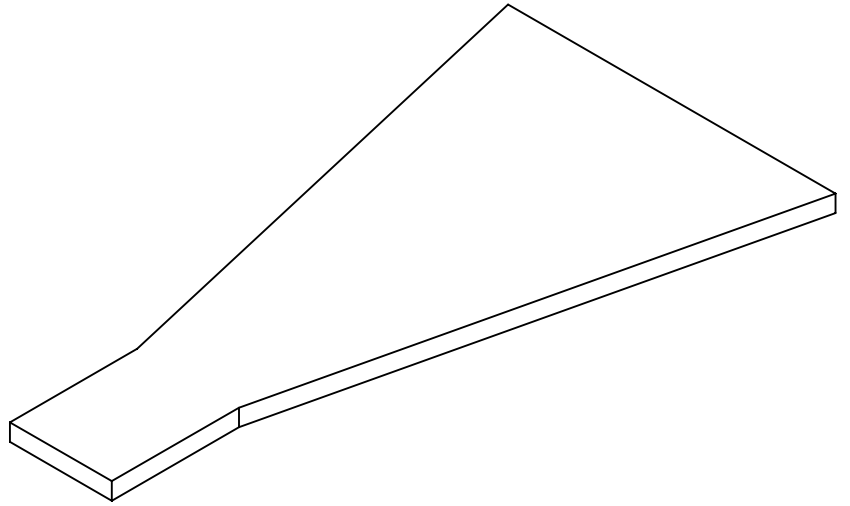
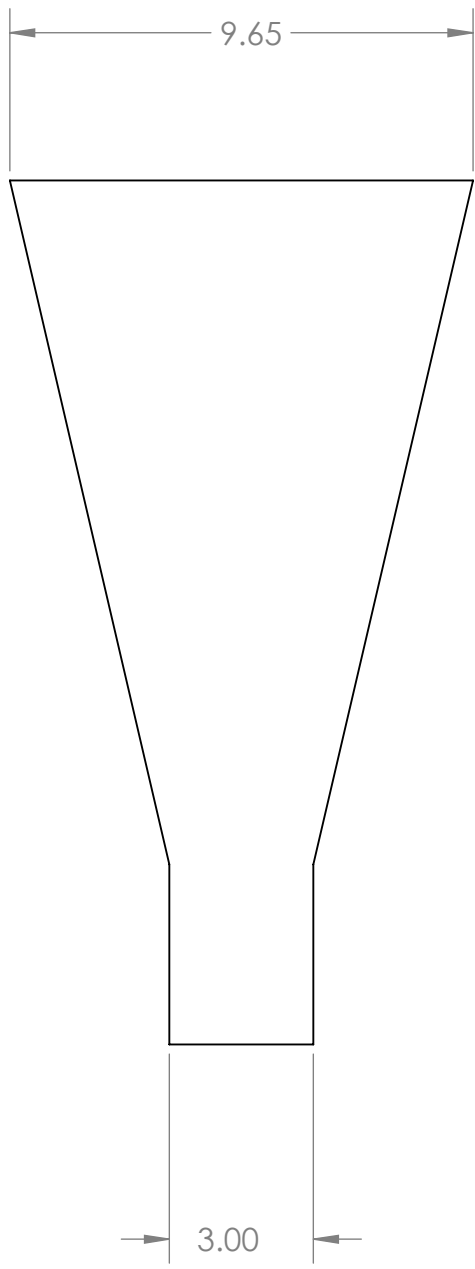

PROPRIETARY AND CONFIDENTIAL
 THE INFORMATION CONTAINED IN THIS DRAWING IS THE SOLE PROPERTY OF <INSERT COMPANY NAME HERE>. ANY REPRODUCTION IN PART OR AS A WHOLE WITHOUT THE WRITTEN PERMISSION OF <INSERT COMPANY NAME HERE> IS PROHIBITED.

		UNLESS OTHERWISE SPECIFIED:		NAME	DATE		
		DIMENSIONS ARE IN INCHES		DRAWN	NJH	11/7/12	TITLE: SEATING ASSEMBLY
		TOLERANCES:		CHECKED	NJH	11/7/12	
		FRACTIONAL ±		ENG APPR.			
		ANGULAR: MACH ± BEND ±		MFG APPR.			
		TWO PLACE DECIMAL ± 0.01		Q.A.			SIZE DWG. NO. REV B BACK REST
		THREE PLACE DECIMAL ±		COMMENTS:			
		INTERPRET GEOMETRIC TOLERANCING PER: N/A					SCALE: 1:4
		MATERIAL: PLYWOOD - PINE					WEIGHT: 496 g
NEXT ASSY	USED ON	FINISH: N/A					SHEET 1 OF 1
APPLICATION		DO NOT SCALE DRAWING					

8 7 6 5 4 3 2 1

D
C
B
A

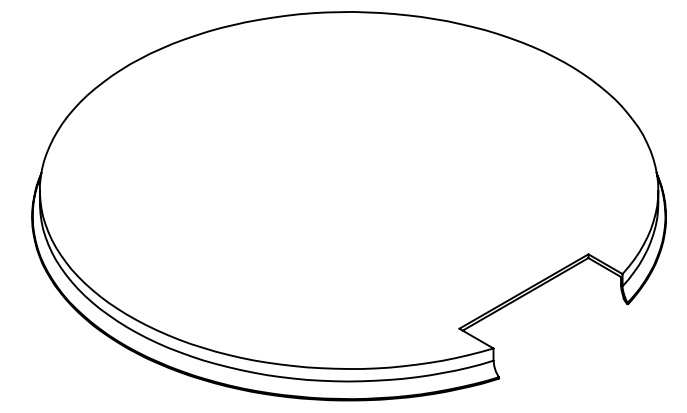
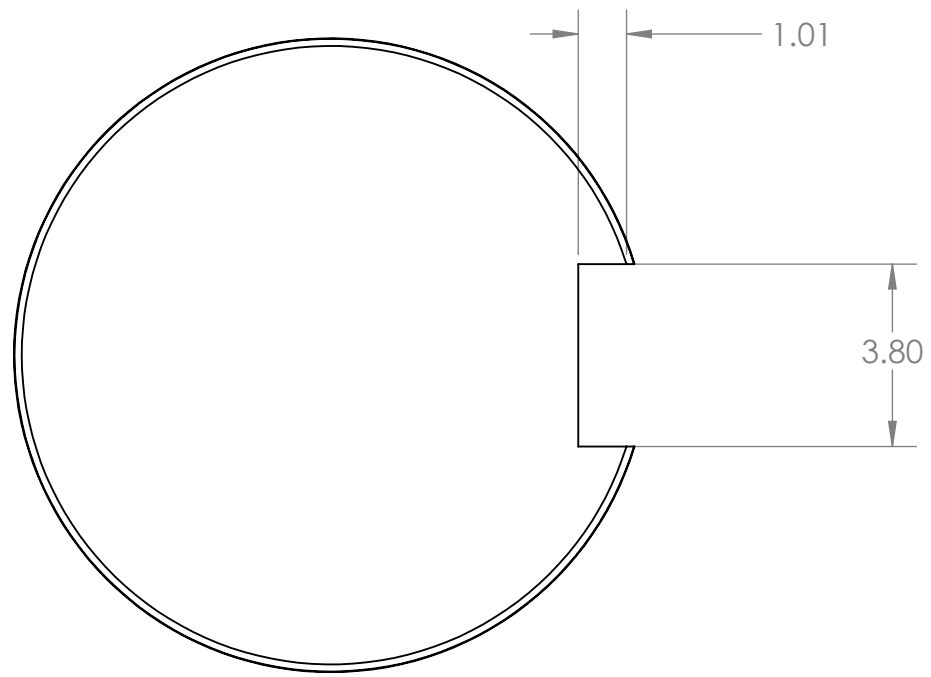

PROPRIETARY AND CONFIDENTIAL
 THE INFORMATION CONTAINED IN THIS DRAWING IS THE SOLE PROPERTY OF <INSERT COMPANY NAME HERE>. ANY REPRODUCTION IN PART OR AS A WHOLE WITHOUT THE WRITTEN PERMISSION OF <INSERT COMPANY NAME HERE> IS PROHIBITED.

		UNLESS OTHERWISE SPECIFIED:		NAME	DATE	TITLE: SEATING ASSEMBLY	
		DIMENSIONS ARE IN INCHES	DRAWN	NJH	11/7/12		
		TOLERANCES:	CHECKED	NJH	11/7/12		
		FRACTIONAL ±	ENG APPR.				
		ANGULAR: MACH ± BEND ±	MFG APPR.				
		TWO PLACE DECIMAL ± 0.01	Q.A.			SIZE B	
		THREE PLACE DECIMAL ±	COMMENTS:				DWG. NO. BUCKET LID
		INTERPRET GEOMETRIC TOLERANCING PER: N/A					REV
		MATERIAL: LOWES PLASTIC (POLYPROPYLENE)				SCALE: 1:4	
		FINISH: N/A				WEIGHT: 368 g	
NEXT ASSY	USED ON					SHEET 1 OF 1	
APPLICATION		DO NOT SCALE DRAWING					

8 7 6 5 4 3 2 1

8 7 6 5 4 3 2 1

D

D

C

C

B

B

A

A

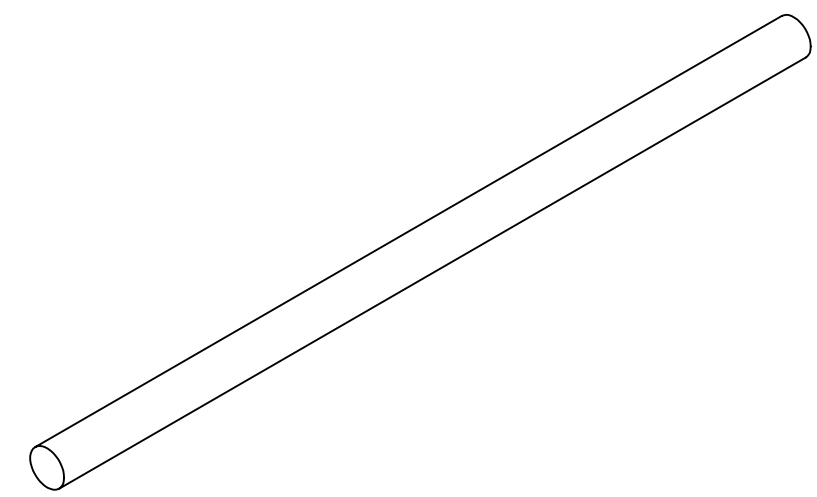
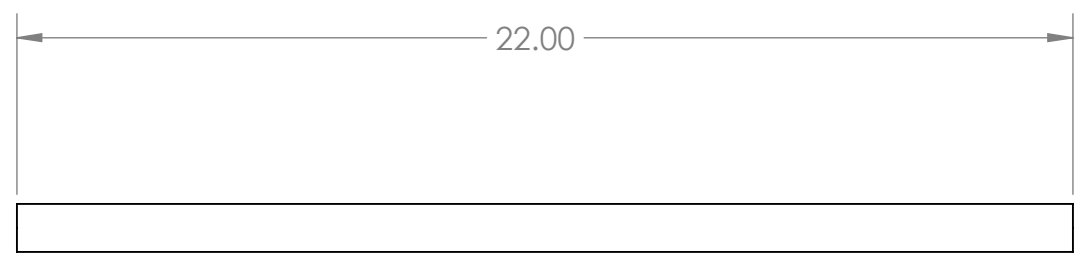
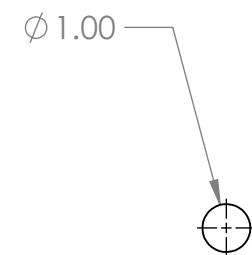

PROPRIETARY AND CONFIDENTIAL
 THE INFORMATION CONTAINED IN THIS DRAWING IS THE SOLE PROPERTY OF <INSERT COMPANY NAME HERE>. ANY REPRODUCTION IN PART OR AS A WHOLE WITHOUT THE WRITTEN PERMISSION OF <INSERT COMPANY NAME HERE> IS PROHIBITED.

		UNLESS OTHERWISE SPECIFIED:		NAME	DATE	TITLE: SEATING ASSEMBLY
		DIMENSIONS ARE IN INCHES	DRAWN	NJH	11/7/12	
		TOLERANCES:	CHECKED	NJH	11/7/12	
		FRACTIONAL ±	ENG APPR.			
		ANGULAR: MACH ± BEND ±	MFG APPR.			
		TWO PLACE DECIMAL ±0.1	Q.A.			SIZE DWG. NO. REV B DOWEL HANDLE
		THREE PLACE DECIMAL ±	COMMENTS:			
		INTERPRET GEOMETRIC TOLERANCING PER: N/A				
		MATERIAL: PINE DOWEL				SCALE: 1:4 WEIGHT: 168 g SHEET 1 OF 1
		FINISH: N/A				
NEXT ASSY	USED ON					
APPLICATION		DO NOT SCALE DRAWING				

8 7 6 5 4 3 2 1

8 7 6 5 4 3 2 1

D
C
B
A

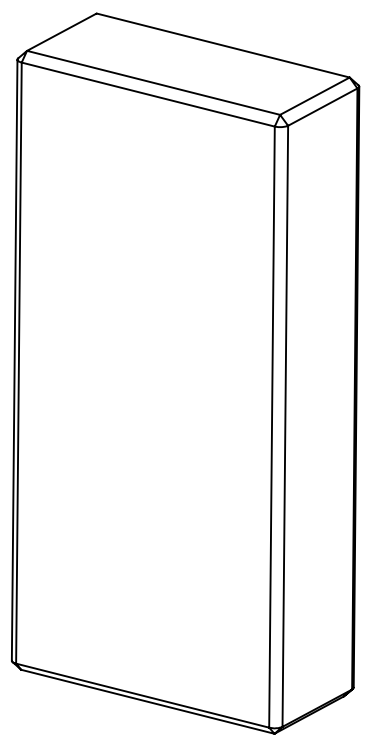
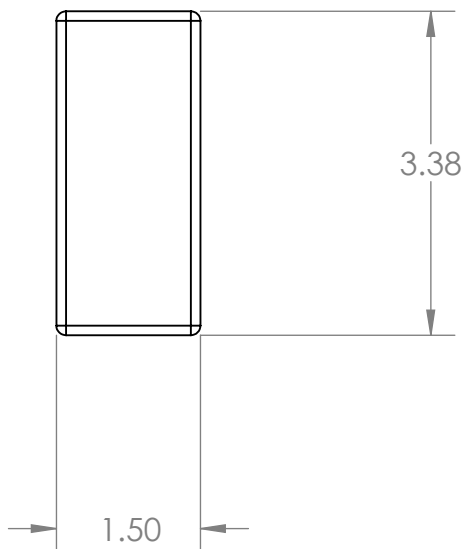
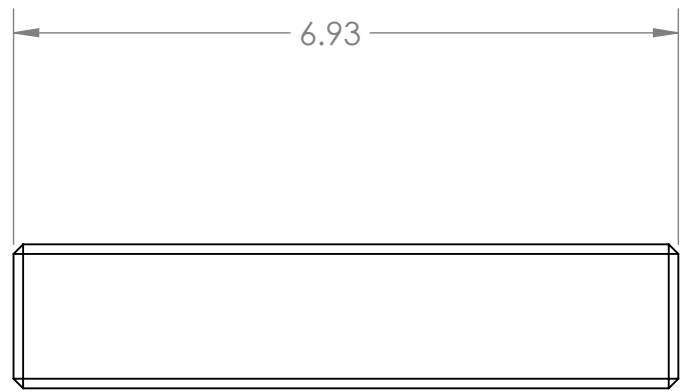

D
C
B
A

PROPRIETARY AND CONFIDENTIAL
 THE INFORMATION CONTAINED IN THIS DRAWING IS THE SOLE PROPERTY OF <INSERT COMPANY NAME HERE>. ANY REPRODUCTION IN PART OR AS A WHOLE WITHOUT THE WRITTEN PERMISSION OF <INSERT COMPANY NAME HERE> IS PROHIBITED.

		UNLESS OTHERWISE SPECIFIED:		NAME	DATE	TITLE: SEATING ASSEMBLY
		DIMENSIONS ARE IN INCHES	DRAWN	NJH	11/7/12	
		TOLERANCES:	CHECKED	NJH	11/7/12	
		FRACTIONAL ±	ENG APPR.			
		ANGULAR: MACH ± BEND ±	MFG APPR.			
		TWO PLACE DECIMAL ± .01	Q.A.			SIZE DWG. NO. REV B SUPPORT 2X4
		THREE PLACE DECIMAL ±	COMMENTS:			
APPLICATION	DO NOT SCALE DRAWING					
INTERPRET GEOMETRIC TOLERANCING PER: N/A						SCALE: 1:1 WEIGHT: 344 g SHEET 1 OF 1
MATERIAL: WHITE PINE						
FINISH: N/A						
NEXT ASSY	USED ON					

8 7 6 5 4 3 2 1

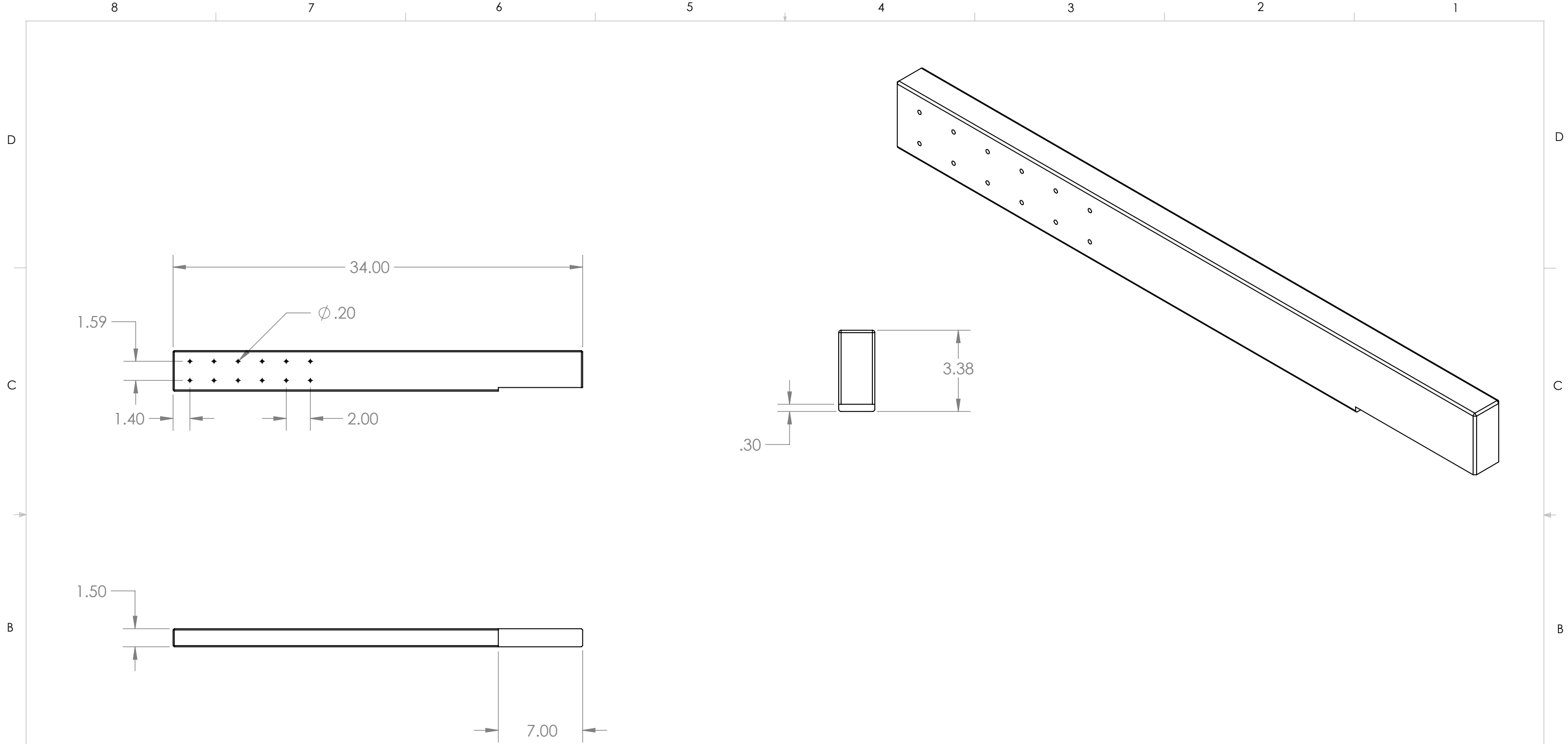

PROPRIETARY AND CONFIDENTIAL
 THE INFORMATION CONTAINED IN THIS DRAWING IS THE SOLE PROPERTY OF <INSERT COMPANY NAME HERE>. ANY REPRODUCTION IN PART OR AS A WHOLE WITHOUT THE WRITTEN PERMISSION OF <INSERT COMPANY NAME HERE> IS PROHIBITED.

		UNLESS OTHERWISE SPECIFIED: DIMENSIONS ARE IN INCHES TOLERANCES: FRACTIONAL ± ANGULAR: MACH ± BEND ± TWO PLACE DECIMAL ± .01 THREE PLACE DECIMAL ±		NAME	DATE	TITLE: SEATING ASSEMBLY
			DRAWN	NJH	11/7/12	
			CHECKED	NJH	11/7/12	
			ENG APPR.			
		INTERPRET GEOMETRIC TOLERANCING PER: N/A				SIZE DWG. NO. REV B BASE 2X4
		MATERIAL: WHITE PINE				
NEXT ASSY	USED ON	FINISH: N/A				SCALE: 1:4 WEIGHT: 1650 g SHEET 1 OF 1
APPLICATION		DO NOT SCALE DRAWING				

8 7 6 5 4 3 2 1

D
C
B
A

D
C
B
A

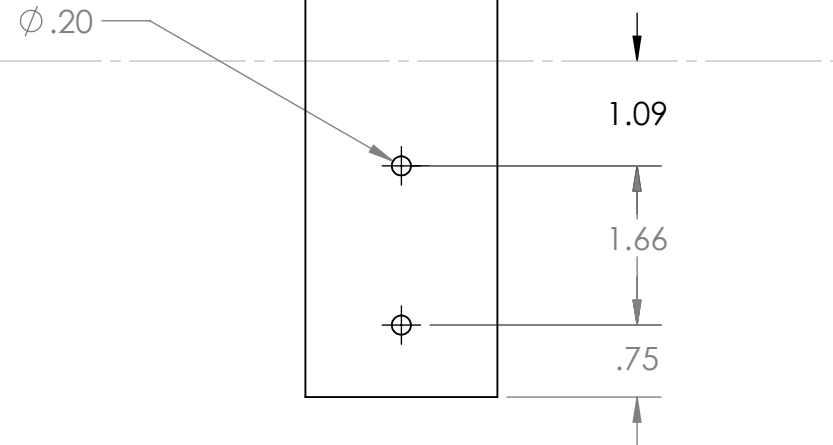
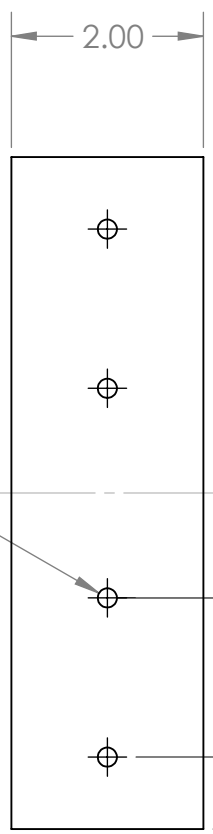
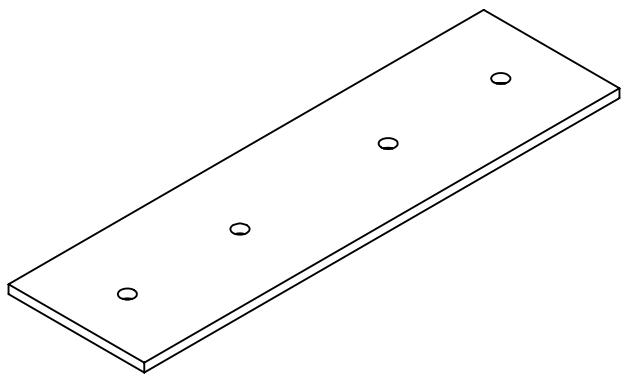

PROPRIETARY AND CONFIDENTIAL
 THE INFORMATION CONTAINED IN THIS DRAWING IS THE SOLE PROPERTY OF <INSERT COMPANY NAME HERE>. ANY REPRODUCTION IN PART OR AS A WHOLE WITHOUT THE WRITTEN PERMISSION OF <INSERT COMPANY NAME HERE> IS PROHIBITED.

		UNLESS OTHERWISE SPECIFIED:		NAME	DATE	TITLE: SEATING ASSEMBLY
		DIMENSIONS ARE IN INCHES TOLERANCES: FRACTIONAL ± ANGULAR: MACH ± BEND ± TWO PLACE DECIMAL ± THREE PLACE DECIMAL ± .001		DRAWN	NJH 11/7/12	
		INTERPRET GEOMETRIC TOLERANCING PER: N/A		CHECKED	NJH 11/7/12	
		MATERIAL: STEEL		ENG APPR.		
NEXT ASSY		USED ON		MFG APPR.		SIZE B
APPLICATION		DO NOT SCALE DRAWING		Q.A.		
				COMMENTS:		REV
						SCALE: 1:2
						WEIGHT: 390 g
						SHEET 1 OF 1

8 7 6 5 4 3 2 1

