

R·I·T

2014

Jib Transfer System



***CAD Drawings for
Manufacture &
Assembly Instructions***

Rochester Institute of Technology

Senior Design Team P14031

5/13/2014

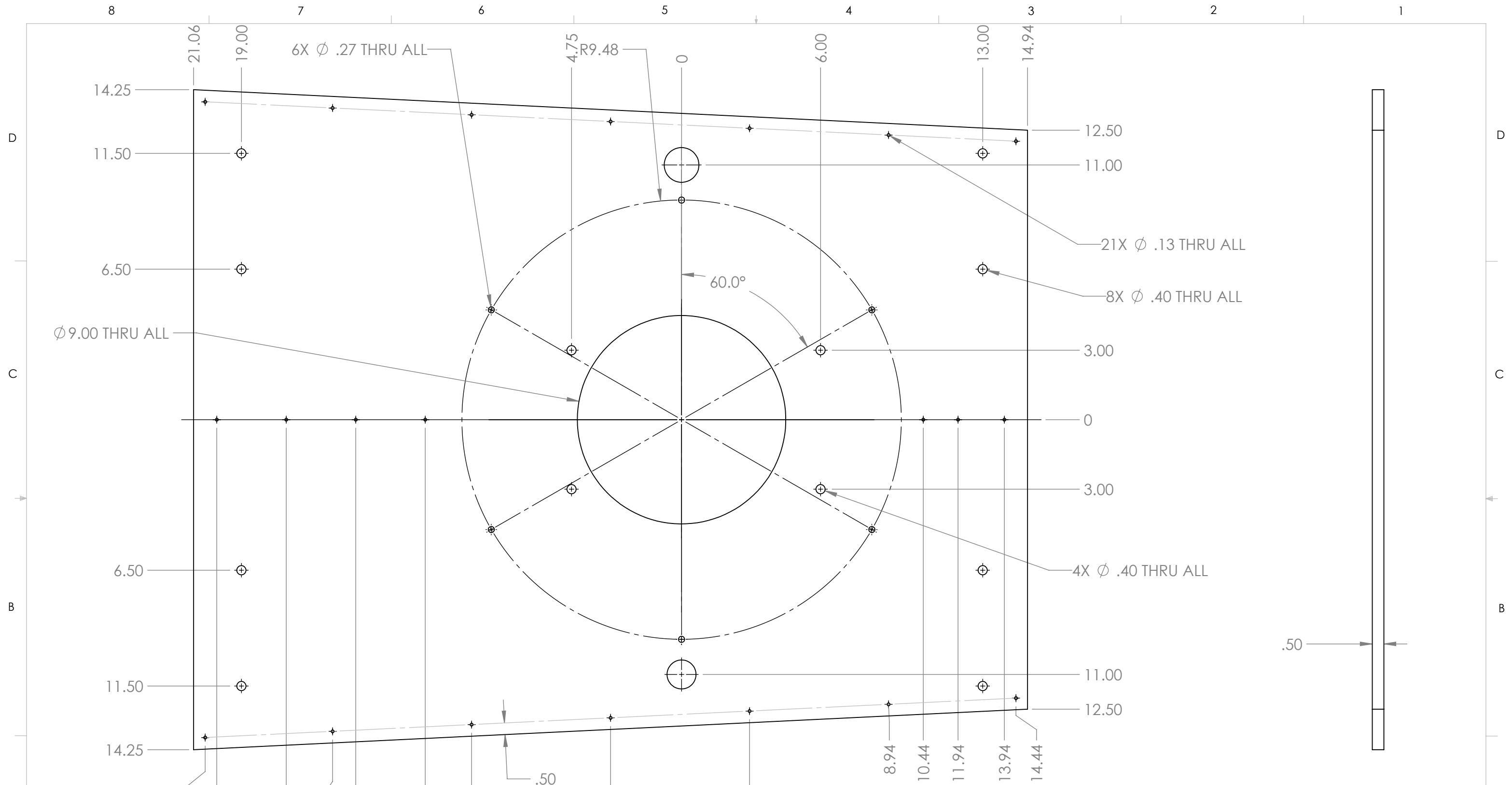

UNLESS OTHERWISE SPECIFIED:		NAME	DATE	RIT MSD Jib Transfer Bench	
DIMENSIONS ARE IN INCHES		DRAWN	MJB		
TOLERANCES:		CHECKED		TITLE:	
ANGULAR: MACH \pm 3deg		ENG APPR.			
TWO PLACE DECIMAL \pm 0.01		MFG APPR.		SIZE DWG. NO. REV	
THREE PLACE DECIMAL \pm 0.001		Q.A.			
INTERPRET GEOMETRIC TOLERANCING PER:		COMMENTS:		B Base	
MATERIAL					
MARINE PLYWOOD				SCALE: 1:4 WEIGHT: SHEET 1 OF 7	
FINISH					
NEXT ASSY	USED ON				
APPLICATION		DO NOT SCALE DRAWING			

PROPRIETARY AND CONFIDENTIAL
 THE INFORMATION CONTAINED IN THIS DRAWING IS THE SOLE PROPERTY OF RIT-KGCOE. ANY REPRODUCTION IN PART OR AS A WHOLE WITHOUT THE WRITTEN PERMISSION OF RIT-KGCOE IS PROHIBITED.

**SolidWorks Educational Edition.
 For Instructional Use Only.**

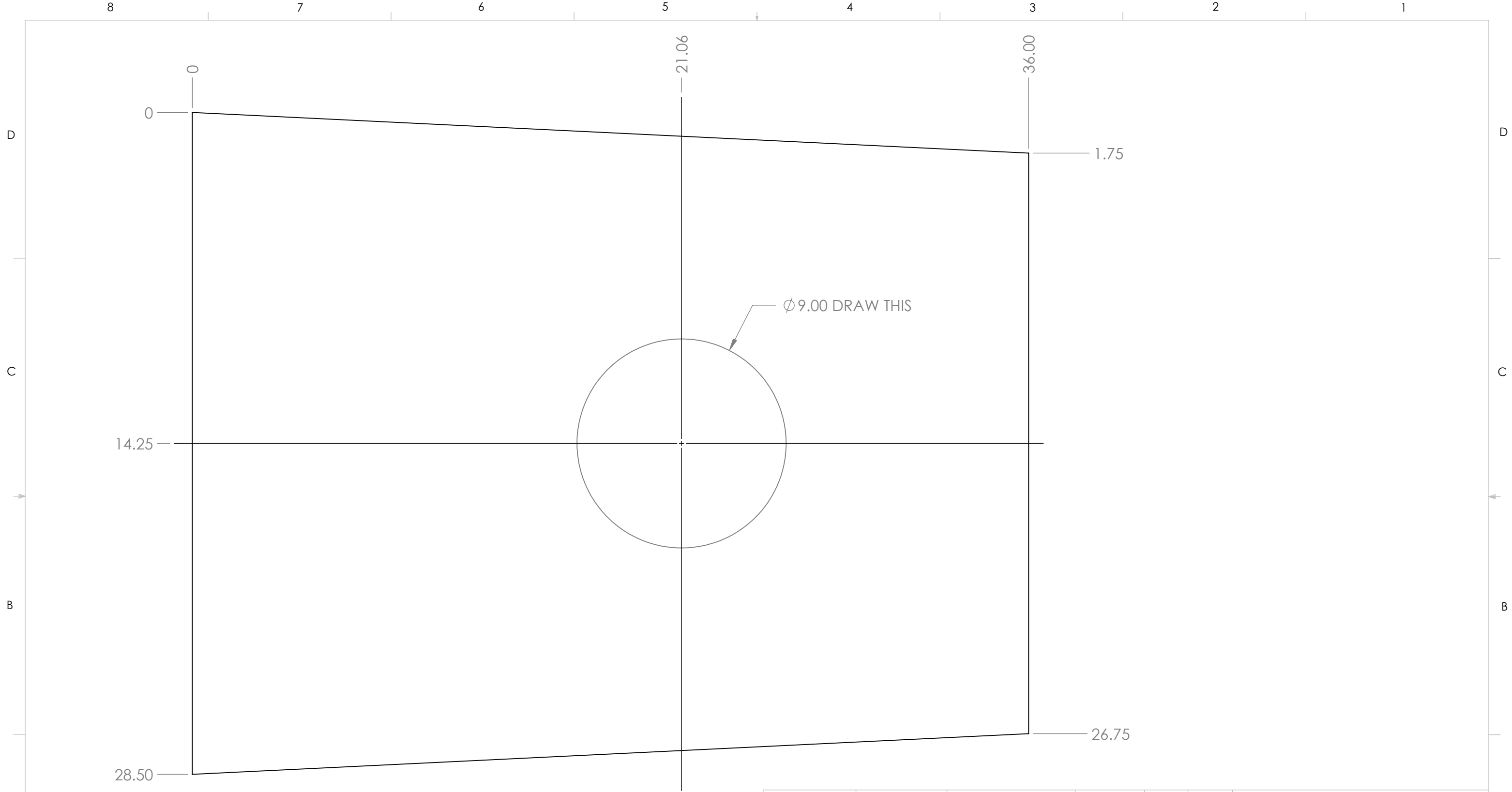

**SolidWorks Educational Edition.
For Instructional Use Only.**

PROPRIETARY AND CONFIDENTIAL
THE INFORMATION CONTAINED IN THIS DRAWING IS THE SOLE PROPERTY OF RIT-KGCOE. ANY REPRODUCTION IN PART OR AS A WHOLE WITHOUT THE WRITTEN PERMISSION OF RIT-KGCOE IS PROHIBITED.

		UNLESS OTHERWISE SPECIFIED:		NAME	DATE	RIT MSD Jib Transfer Bench			
		DIMENSIONS ARE IN INCHES TOLERANCES: ANGULAR: MACH $\pm 3\text{deg}$ TWO PLACE DECIMAL ± 0.01 THREE PLACE DECIMAL ± 0.001		DRAWN	MJB			4/19/14	
				CHECKED			TITLE: Base_1		
				ENG APPR.					
				MFG APPR.					
				Q.A.					
				COMMENTS:			SIZE	DWG. NO.	REV
NEXT ASSY		USED ON					B	Base	
APPLICATION		DO NOT SCALE DRAWING					SCALE: 1:4	WEIGHT:	SHEET 2 OF 7

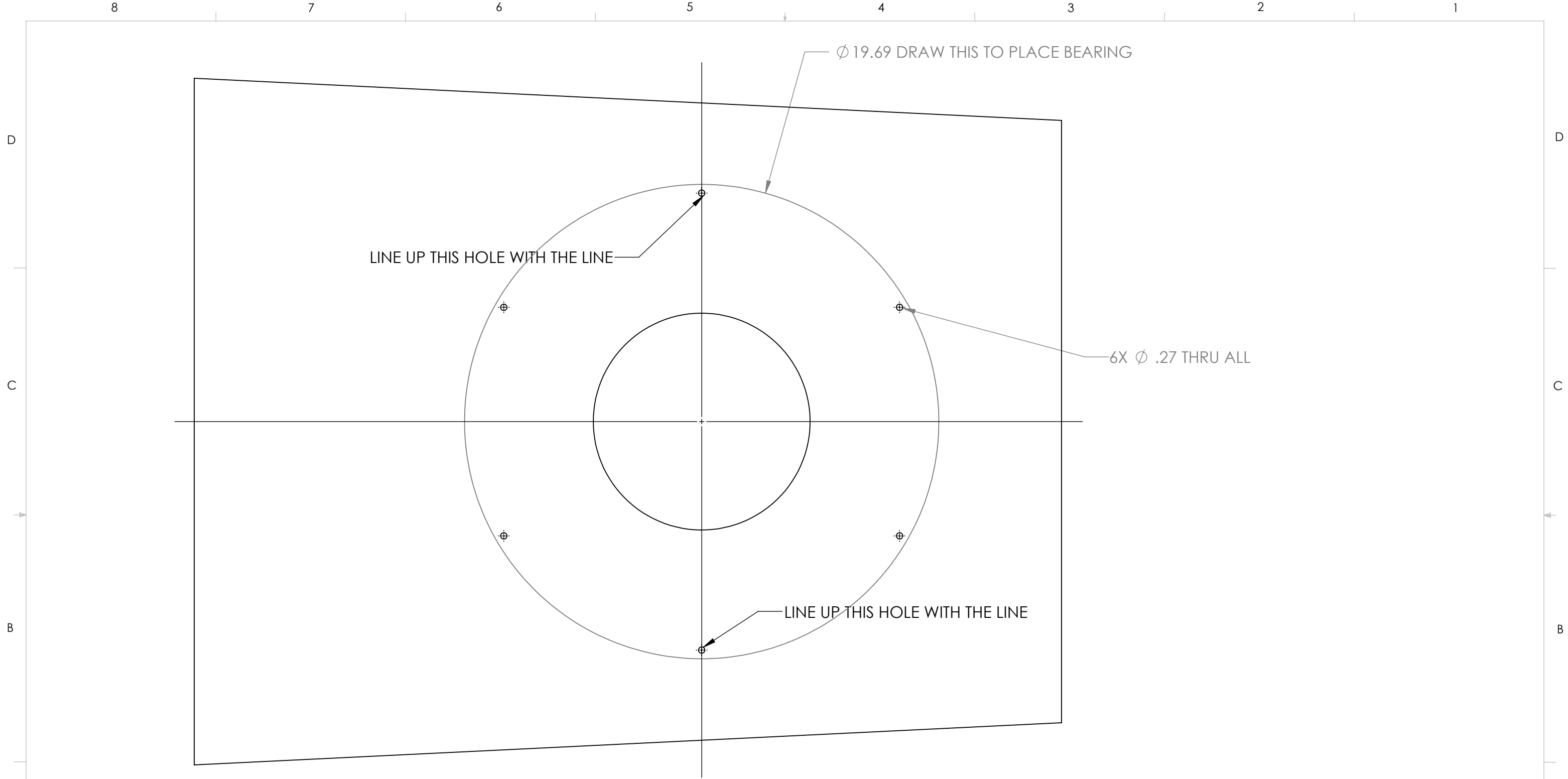

		UNLESS OTHERWISE SPECIFIED:		NAME	DATE	RIT MSD Jib Transfer Bench	
		DIMENSIONS ARE IN INCHES		DRAWN	MJB	4/19/14	TITLE: Base_2
		TOLERANCES:		CHECKED			
		ANGULAR: MACH ±3deg		ENG APPR.			
		TWO PLACE DECIMAL ±0.01		MFG APPR.			
		THREE PLACE DECIMAL ±0.001		Q.A.			SIZE DWG. NO. REV B Base
		INTERPRET GEOMETRIC TOLERANCING PER:		COMMENTS:			
		MATERIAL					SCALE: 1:4 WEIGHT: SHEET 3 OF 7
		FINISH					
NEXT ASSY	USED ON	DO NOT SCALE DRAWING					
APPLICATION							

PROPRIETARY AND CONFIDENTIAL
 THE INFORMATION CONTAINED IN THIS DRAWING IS THE SOLE PROPERTY OF RIT-KGCOE. ANY REPRODUCTION IN PART OR AS A WHOLE WITHOUT THE WRITTEN PERMISSION OF RIT-KGCOE IS PROHIBITED.

**SolidWorks Educational Edition.
 For Instructional Use Only.**

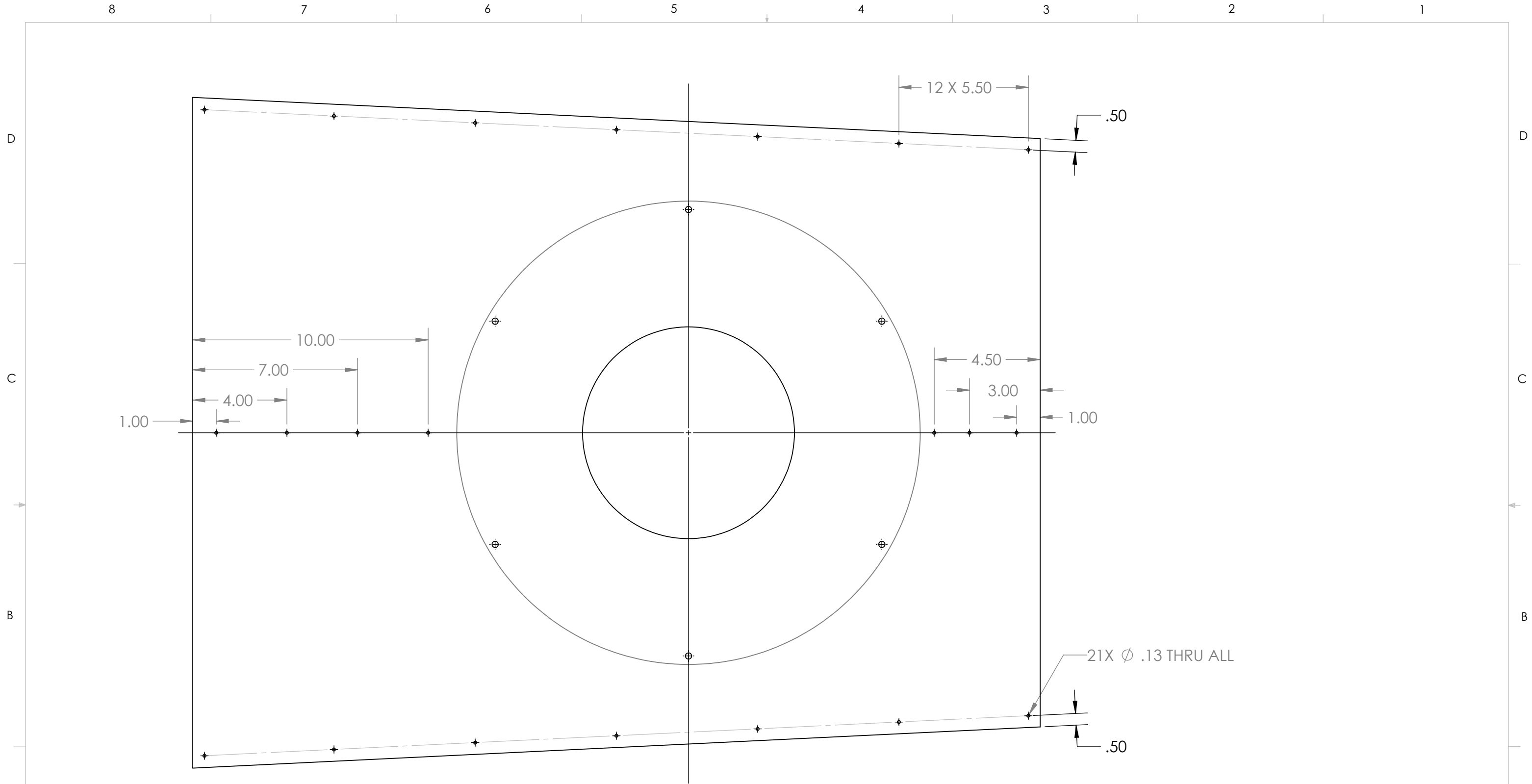

**SolidWorks Educational Edition.
For Instructional Use Only.**

PROPRIETARY AND CONFIDENTIAL
THE INFORMATION CONTAINED IN THIS DRAWING IS THE SOLE PROPERTY OF RIT-KGCOE. ANY REPRODUCTION IN PART OR AS A WHOLE WITHOUT THE WRITTEN PERMISSION OF RIT-KGCOE IS PROHIBITED.

		UNLESS OTHERWISE SPECIFIED:		NAME	DATE	RIT MSD Jib Transfer Bench	
		DIMENSIONS ARE IN INCHES TOLERANCES: ANGULAR: MACH ±3deg TWO PLACE DECIMAL ±0.01 THREE PLACE DECIMAL ±0.001		DRAWN	MJB		
		INTERPRET GEOMETRIC TOLERANCING PER:		CHECKED		TITLE: Base_3	
		MATERIAL		ENG APPR.			
NEXT ASSY		USED ON		MFG APPR.		SIZE DWG. NO. REV	
APPLICATION		DO NOT SCALE DRAWING		Q.A.		B Base	
				COMMENTS:			
						SCALE: 1:4 WEIGHT: SHEET 4 OF 7	

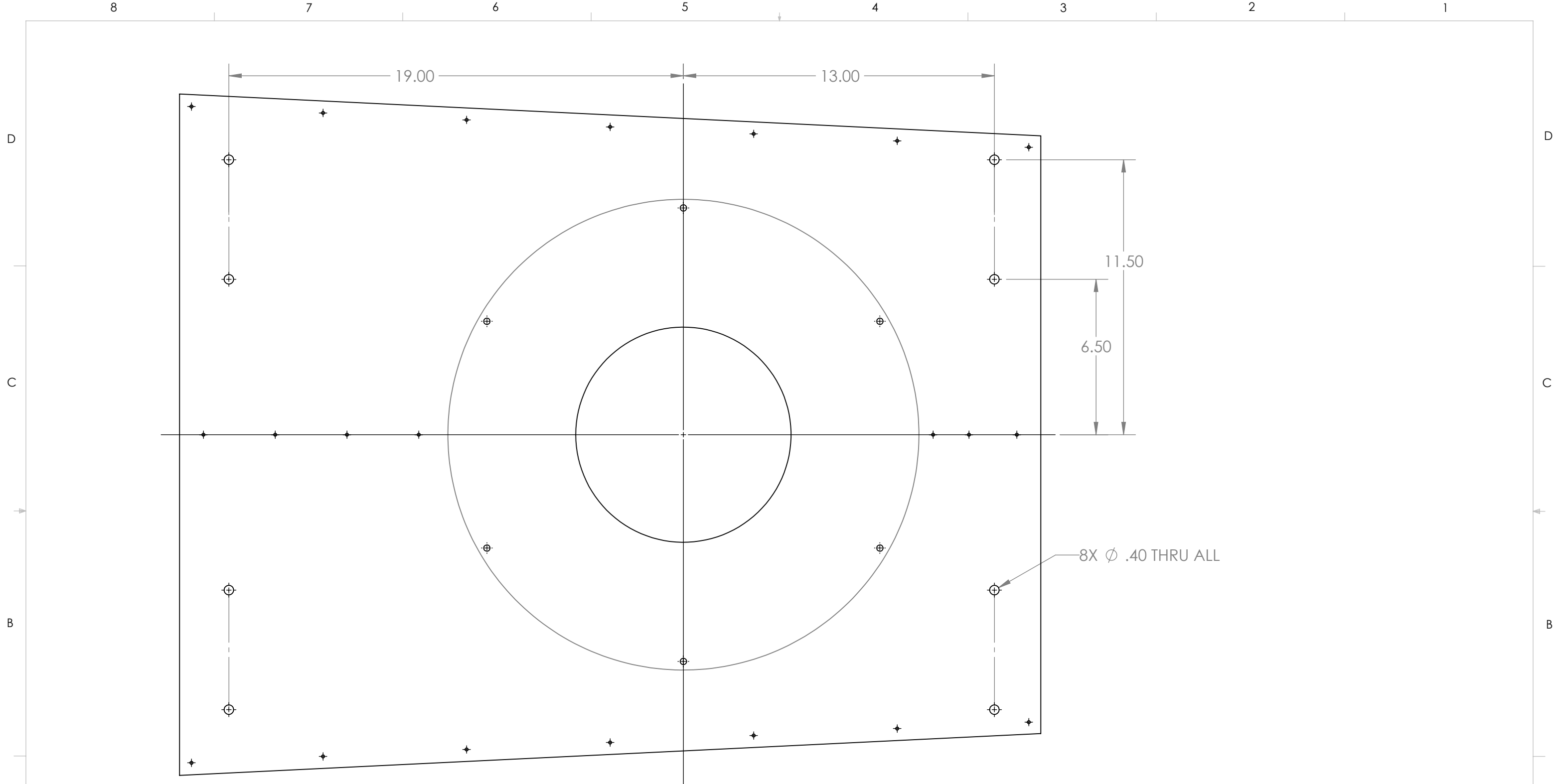

**SolidWorks Educational Edition.
For Instructional Use Only.**

PROPRIETARY AND CONFIDENTIAL
THE INFORMATION CONTAINED IN THIS DRAWING IS THE SOLE PROPERTY OF RIT-KGCOE. ANY REPRODUCTION IN PART OR AS A WHOLE WITHOUT THE WRITTEN PERMISSION OF RIT-KGCOE IS PROHIBITED.

		UNLESS OTHERWISE SPECIFIED:		NAME	DATE	RIT MSD Jib Transfer Bench			
		DIMENSIONS ARE IN INCHES		DRAWN	MJB			4/19/14	
		TOLERANCES:		CHECKED			TITLE: Base_4		
		ANGULAR: MACH ±3deg		ENG APPR.					
		TWO PLACE DECIMAL ±0.01		MFG APPR.					
		THREE PLACE DECIMAL ±0.001		Q.A.					
		INTERPRET GEOMETRIC TOLERANCING PER:		COMMENTS:					
		MATERIAL							
		FINISH							
NEXT ASSY	USED ON						SIZE	DWG. NO.	REV
APPLICATION		DO NOT SCALE DRAWING					B	Base	
							SCALE: 1:4	WEIGHT:	SHEET 5 OF 7

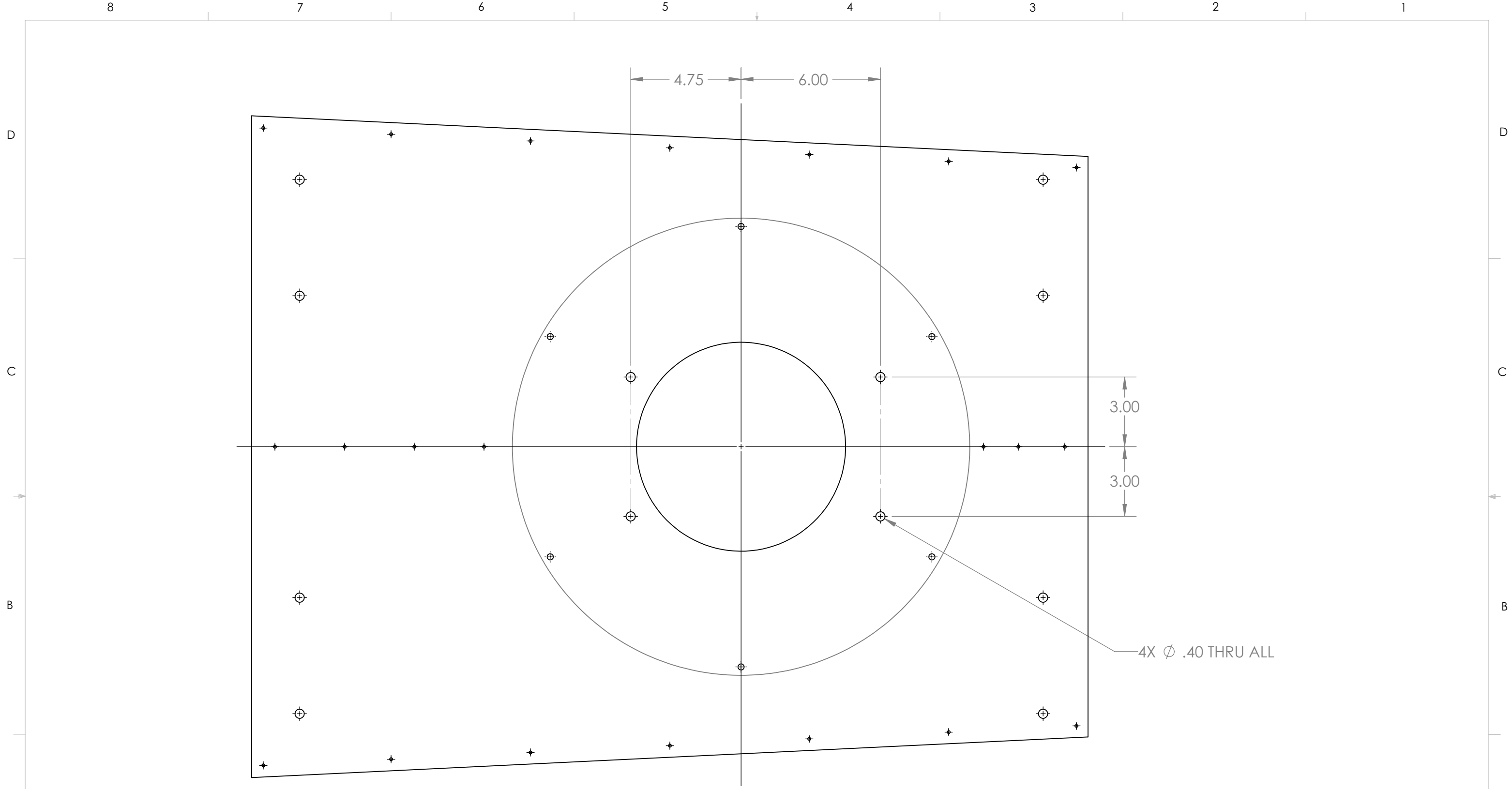

		UNLESS OTHERWISE SPECIFIED:		NAME	DATE	RIT MSD Jib Transfer Bench	
		DIMENSIONS ARE IN INCHES TOLERANCES: ANGULAR: MACH ±3deg TWO PLACE DECIMAL ±0.01 THREE PLACE DECIMAL ±0.001		DRAWN	MJB		
		INTERPRET GEOMETRIC TOLERANCING PER:		CHECKED		TITLE: Base_5	
		MATERIAL		ENG APPR.			
		FINISH		MFG APPR.		SIZE DWG. NO. REV	
NEXT ASSY	USED ON	DO NOT SCALE DRAWING		Q.A.		Base	
APPLICATION				COMMENTS:			
				SCALE: 1:4		WEIGHT:	SHEET 6 OF 7

**SolidWorks Educational Edition.
For Instructional Use Only.**

PROPRIETARY AND CONFIDENTIAL
THE INFORMATION CONTAINED IN THIS
DRAWING IS THE SOLE PROPERTY OF
RIT-KGCOE. ANY REPRODUCTION IN
PART OR AS A WHOLE WITHOUT THE
WRITTEN PERMISSION OF
RIT-KGCOE IS PROHIBITED.

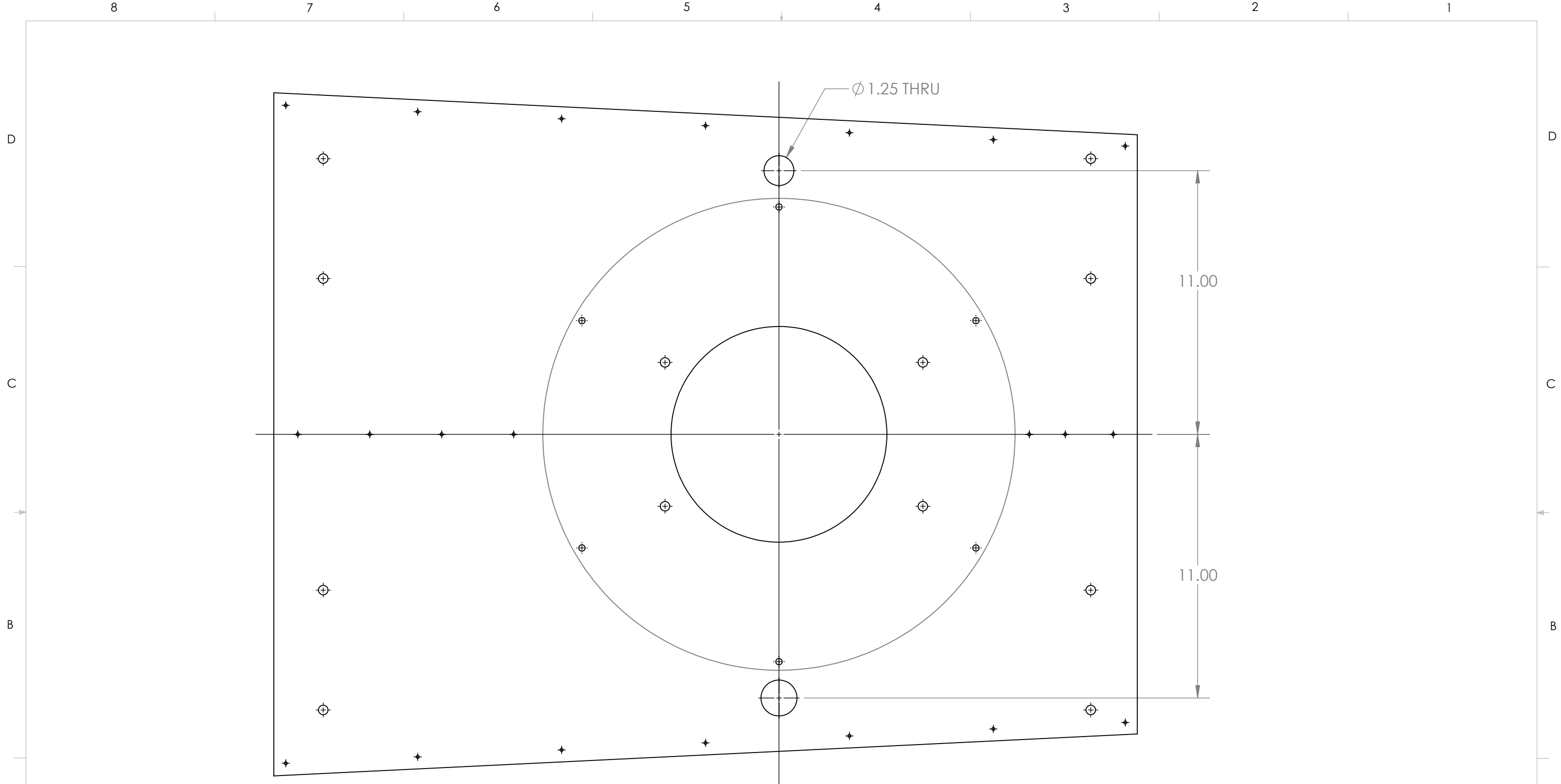

		UNLESS OTHERWISE SPECIFIED:		NAME	DATE
		DIMENSIONS ARE IN INCHES	DRAWN	MJB	4/19/14
		TOLERANCES:	CHECKED		
		ANGULAR: MACH ±3deg	ENG APPR.		
		TWO PLACE DECIMAL ±0.01	MFG APPR.		
		THREE PLACE DECIMAL ±0.001	Q.A.		
		INTERPRET GEOMETRIC TOLERANCING PER:	COMMENTS:		
		MATERIAL			
		FINISH			
NEXT ASSY	USED ON				
APPLICATION		DO NOT SCALE DRAWING			

RIT MSD Jib Transfer Bench		
TITLE:		
Base_6		
SIZE	DWG. NO.	REV
B	Base	
SCALE: 1:4	WEIGHT:	SHEET 7 OF 7

PROPRIETARY AND CONFIDENTIAL
 THE INFORMATION CONTAINED IN THIS DRAWING IS THE SOLE PROPERTY OF RIT-KGCOE. ANY REPRODUCTION IN PART OR AS A WHOLE WITHOUT THE WRITTEN PERMISSION OF RIT-KGCOE IS PROHIBITED.

**SolidWorks Educational Edition.
 For Instructional Use Only.**

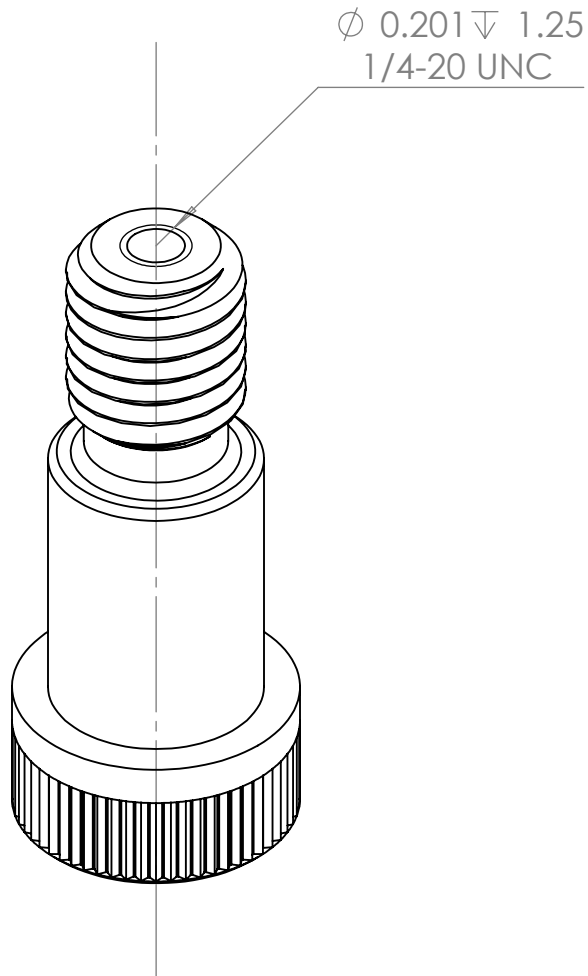

PROPRIETARY AND CONFIDENTIAL
 THE INFORMATION CONTAINED IN THIS DRAWING IS THE SOLE PROPERTY OF RIT-KGCOE. ANY REPRODUCTION, IN PART OR AS A WHOLE WITHOUT THE WRITTEN PERMISSION OF RIT-KGCOE IS PROHIBITED.

SolidWorks Educational Edition.
For Instructional Use Only.

		DIMENSIONS ARE IN INCHES		NAME	DATE	RIT MSD Jib Transfer Bench	
		TOLERANCES:		DRAWN	MJK		4/8/14
		ANGULAR: MACH ± 3 deg		CHECKED			
		TWO PLACE DECIMAL ± 0.01		ENG APPR.			
		THREE PLACE DECIMAL ± 0.001		MFG APPR.			
		MATERIAL		Q.A.			
NEXT ASSY	USED ON	FINISH	COMMENTS:				
APPLICATION		DO NOT SCALE DRAWING				SIZE DWG. NO.	REV.
						A Brake_Bolt_MOD	
						SCALE: 3:2	WEIGHT: SHEET 1 OF 1

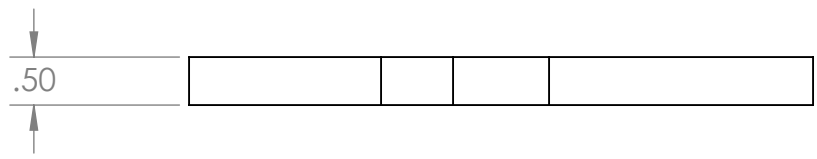
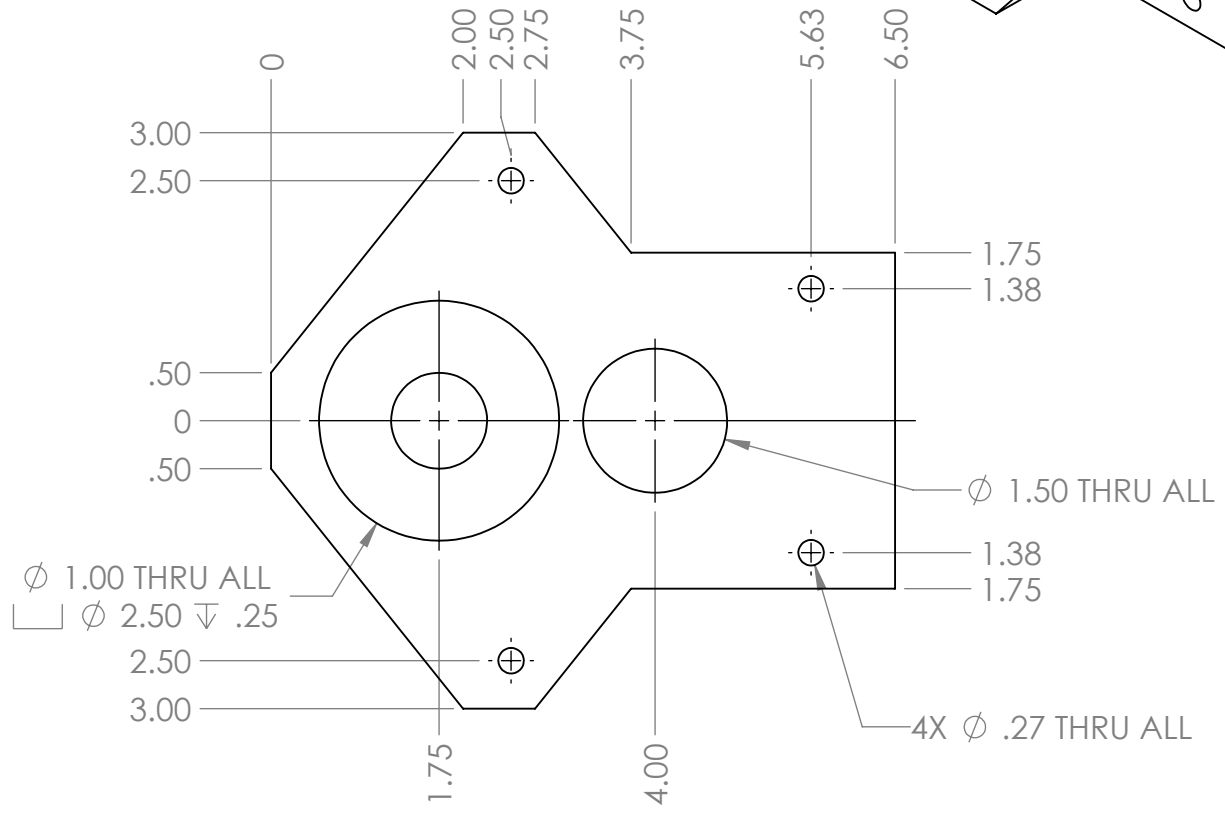
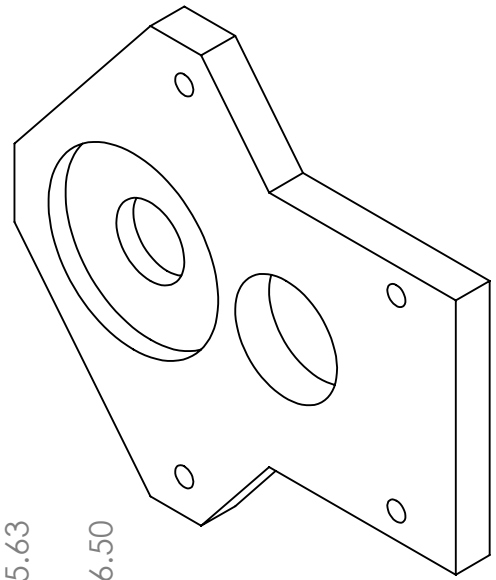

PROPRIETARY AND CONFIDENTIAL
 THE INFORMATION CONTAINED IN THIS DRAWING IS THE SOLE PROPERTY OF RIT-KGCOE. ALL RIGHTS ARE RESERVED. NO PART OR AS A WHOLE WITHOUT THE WRITTEN PERMISSION OF RIT-KGCOE IS PROHIBITED.

SolidWorks Educational Edition.
For Instructional Use Only.

		DIMENSIONS ARE IN INCHES TOLERANCES: ANGULAR: MACH±3deg TWO PLACE DECIMAL ±0.01 THREE PLACE DECIMAL ±0.001
NEXT ASSY	USED ON	MATERIAL MARINE PLYWOOD FINISH
APPLICATION		DO NOT SCALE DRAWING

	NAME	DATE
DRAWN	MJB	12/18/13
CHECKED		
ENG APPR.		
MFG APPR.		
Q.A.		
COMMENTS:		

RIT MSD Jib Transfer Bench		
SIZE	DWG. NO.	REV.
A	Brake_Plate	
SCALE:1:2	WEIGHT:	SHEET 1 OF 1

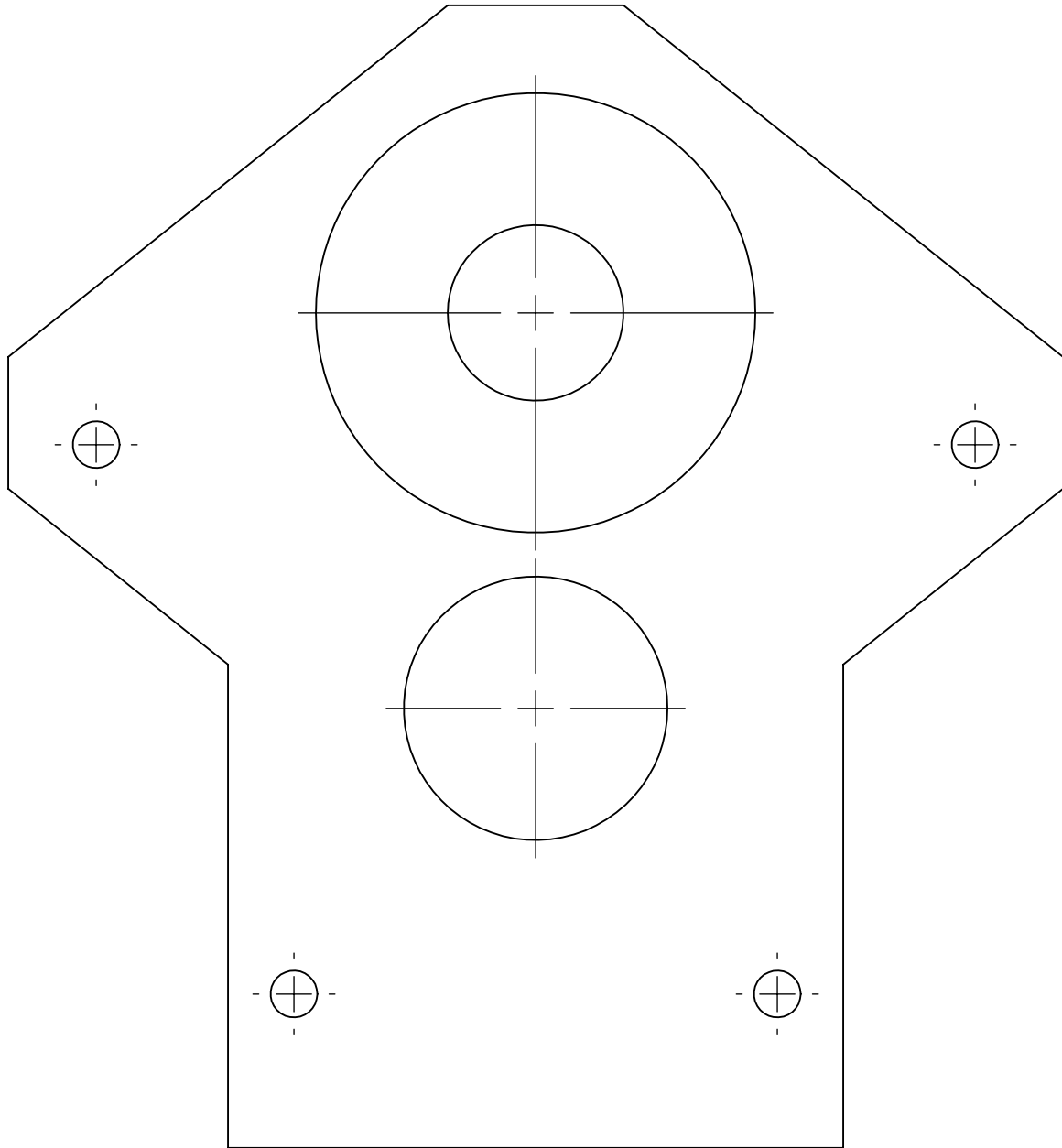

PROPRIETARY AND CONFIDENTIAL
 THE INFORMATION CONTAINED IN THIS DRAWING IS THE SOLE PROPERTY OF RIT-KGCOE. ANY REPRODUCTION, PART OR AS A WHOLE WITHOUT THE WRITTEN PERMISSION OF RIT-KGCOE IS PROHIBITED.

SolidWorks Educational Edition.
For Instructional Use Only.

		DIMENSIONS ARE IN INCHES TOLERANCES: ANGULAR: MACH±3deg TWO PLACE DECIMAL ±0.01 THREE PLACE DECIMAL ±0.001		NAME	DATE	RIT MSD Jib Transfer Bench
		MATERIAL		DRAWN	MJB 4/08/14	
		FINISH		CHECKED		
NEXT ASSY		USED ON		ENG APPR.		
APPLICATION		DO NOT SCALE DRAWING		MFG APPR.		
				Q.A.		
				COMMENTS:		
				SIZE	DWG. NO.	REV.
				A Brake_Plate_Template		
				SCALE:1:1	WEIGHT:	SHEET 1 OF 1

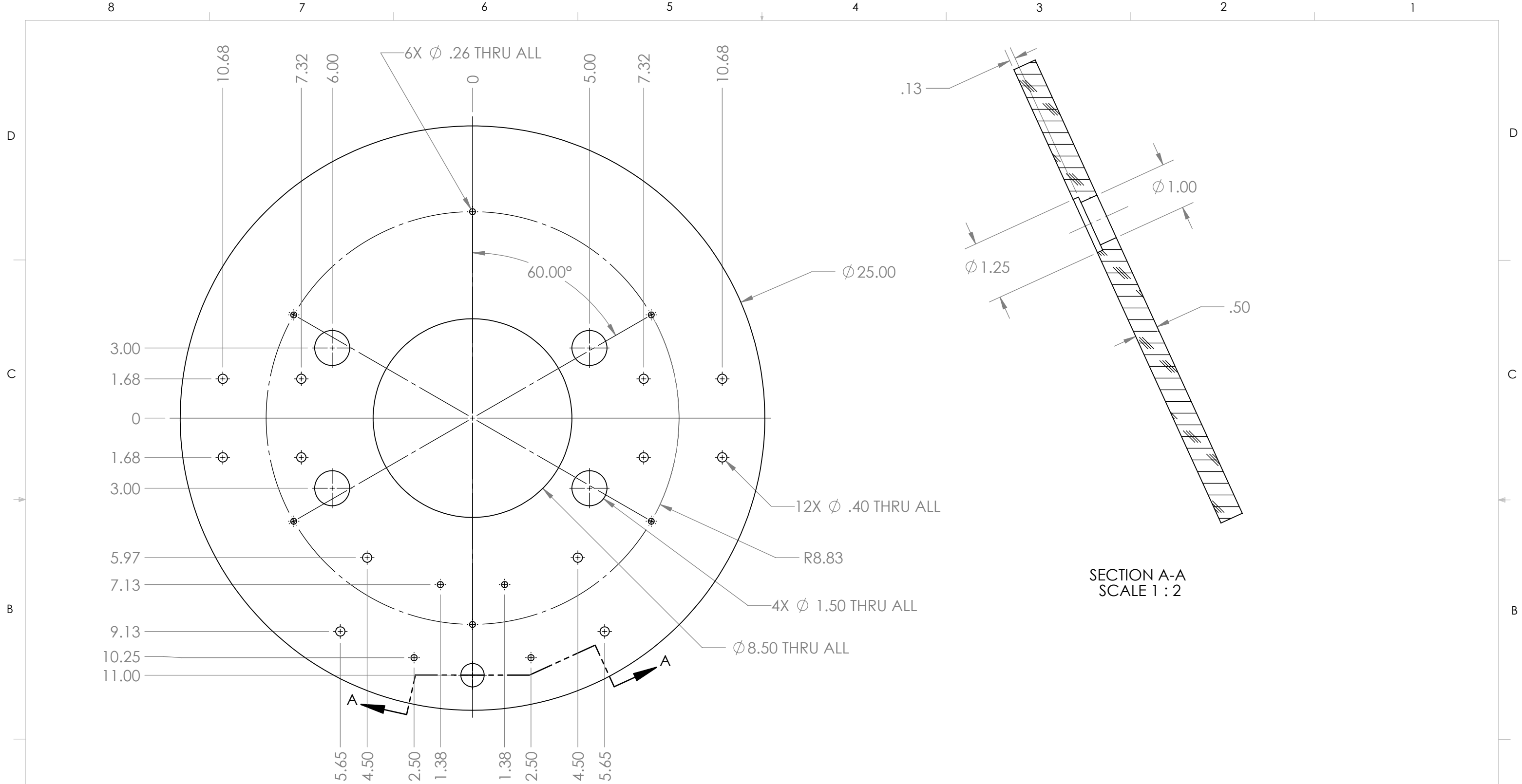

SECTION A-A
SCALE 1 : 2

		UNLESS OTHERWISE SPECIFIED:		NAME	DATE	RIT MSD Jib Transfer Bench	
		DIMENSIONS ARE IN INCHES TOLERANCES: ANGULAR: MACH ±3deg TWO PLACE DECIMAL ±0.01 THREE PLACE DECIMAL ±0.001		DRAWN	MJB		
				CHECKED		TITLE:	
				ENG APPR.			
				MFG APPR.		SIZE DWG. NO. REV	
				Q.A.			
		INTERPRET GEOMETRIC TOLERANCING PER:		COMMENTS:		B Base_Upper	
		MATERIAL MARINE PLYWOOD				SCALE: 1:4 WEIGHT: SHEET 1 OF 7	
		FINISH					
NEXT ASSY	USED ON	DO NOT SCALE DRAWING					
APPLICATION							

PROPRIETARY AND CONFIDENTIAL
THE INFORMATION CONTAINED IN THIS DRAWING IS THE SOLE PROPERTY OF RIT-KGCOE. ANY REPRODUCTION IN PART OR AS A WHOLE WITHOUT THE WRITTEN PERMISSION OF RIT-KGCOE IS PROHIBITED.

**SolidWorks Educational Edition.
For Instructional Use Only.**

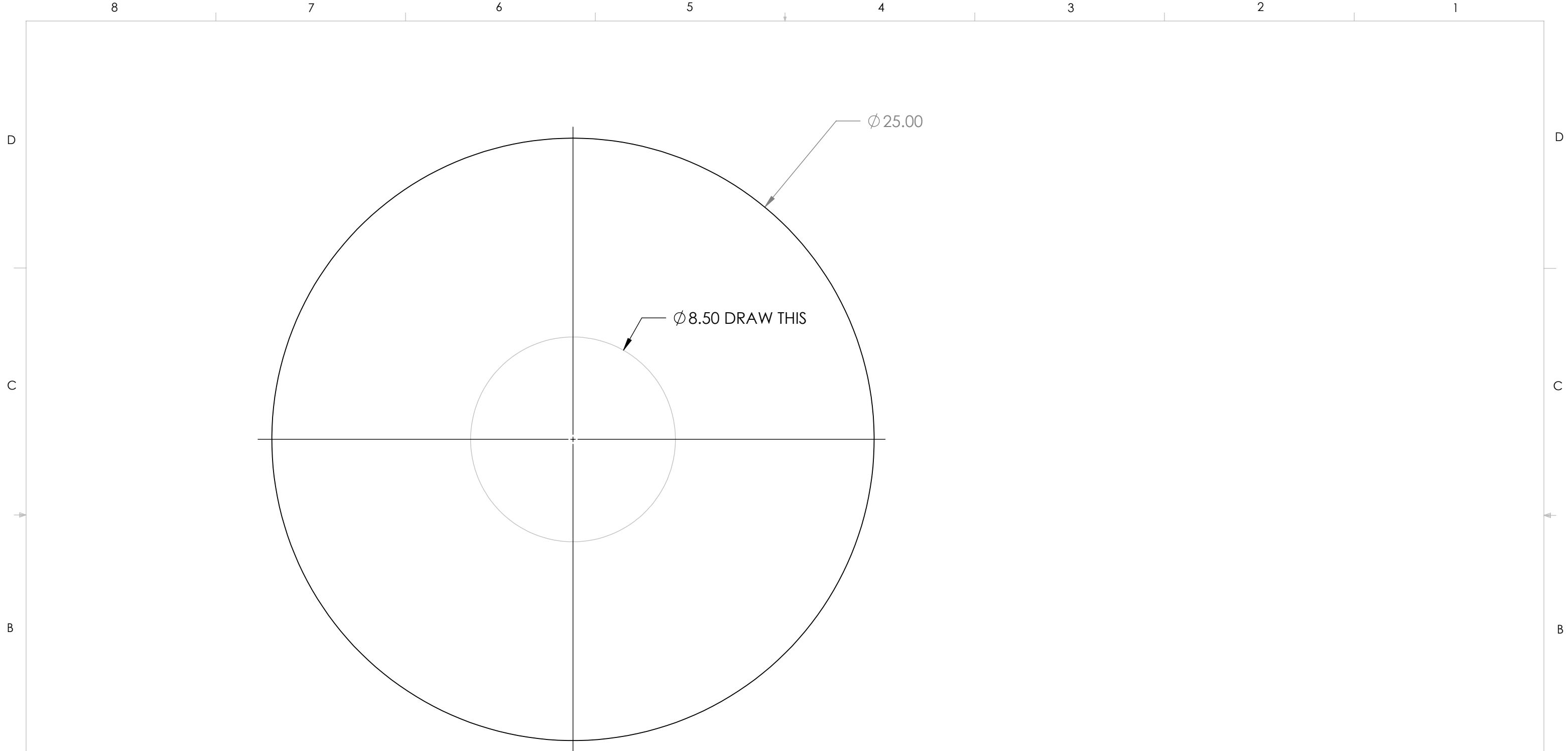

**SolidWorks Educational Edition.
For Instructional Use Only.**

PROPRIETARY AND CONFIDENTIAL
THE INFORMATION CONTAINED IN THIS DRAWING IS THE SOLE PROPERTY OF RIT-KGCOE. ANY REPRODUCTION IN PART OR AS A WHOLE WITHOUT THE WRITTEN PERMISSION OF RIT-KGCOE IS PROHIBITED.

		UNLESS OTHERWISE SPECIFIED:		NAME	DATE	RIT MSD Jib Transfer Bench	
		DIMENSIONS ARE IN INCHES	DRAWN	MJB	4/19/14		
		TOLERANCES: ANGULAR: MACH ±3deg	CHECKED			SIZE DWG. NO. REV B Base_Upper	
		TWO PLACE DECIMAL ±0.01	ENG APPR.				
		THREE PLACE DECIMAL ±0.001	MFG APPR.				
		INTERPRET GEOMETRIC TOLERANCING PER:	Q.A.				
		MATERIAL	COMMENTS:				
NEXT ASSY	USED ON	FINISH					
APPLICATION		DO NOT SCALE DRAWING					

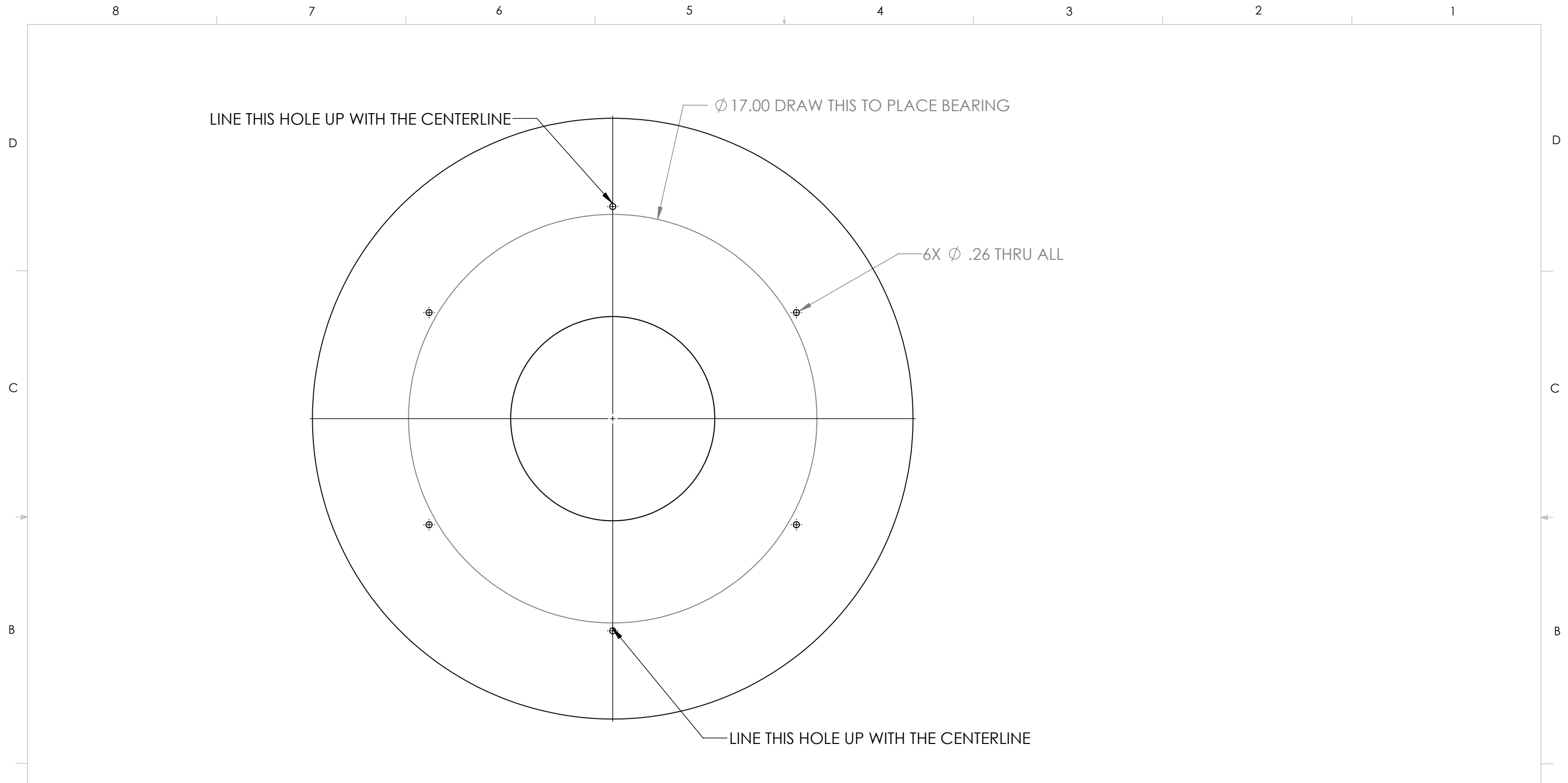

**SolidWorks Educational Edition.
For Instructional Use Only.**

PROPRIETARY AND CONFIDENTIAL
THE INFORMATION CONTAINED IN THIS DRAWING IS THE SOLE PROPERTY OF RIT-KGCOE. ANY REPRODUCTION IN PART OR AS A WHOLE WITHOUT THE WRITTEN PERMISSION OF RIT-KGCOE IS PROHIBITED.

		UNLESS OTHERWISE SPECIFIED:		NAME	DATE	RIT MSD Jib Transfer Bench	
		DIMENSIONS ARE IN INCHES TOLERANCES: ANGULAR: MACH ±3deg TWO PLACE DECIMAL ±0.01 THREE PLACE DECIMAL ±0.001		DRAWN	MJB		
		INTERPRET GEOMETRIC TOLERANCING PER:		CHECKED		UpperBase_2	
		MATERIAL		ENG APPR.			
		FINISH		MFG APPR.		SIZE DWG. NO. REV	
NEXT ASSY	USED ON	DO NOT SCALE DRAWING		Q.A.		B Base_Upper	
APPLICATION				COMMENTS:		SCALE: 1:4 WEIGHT: SHEET 3 OF 7	

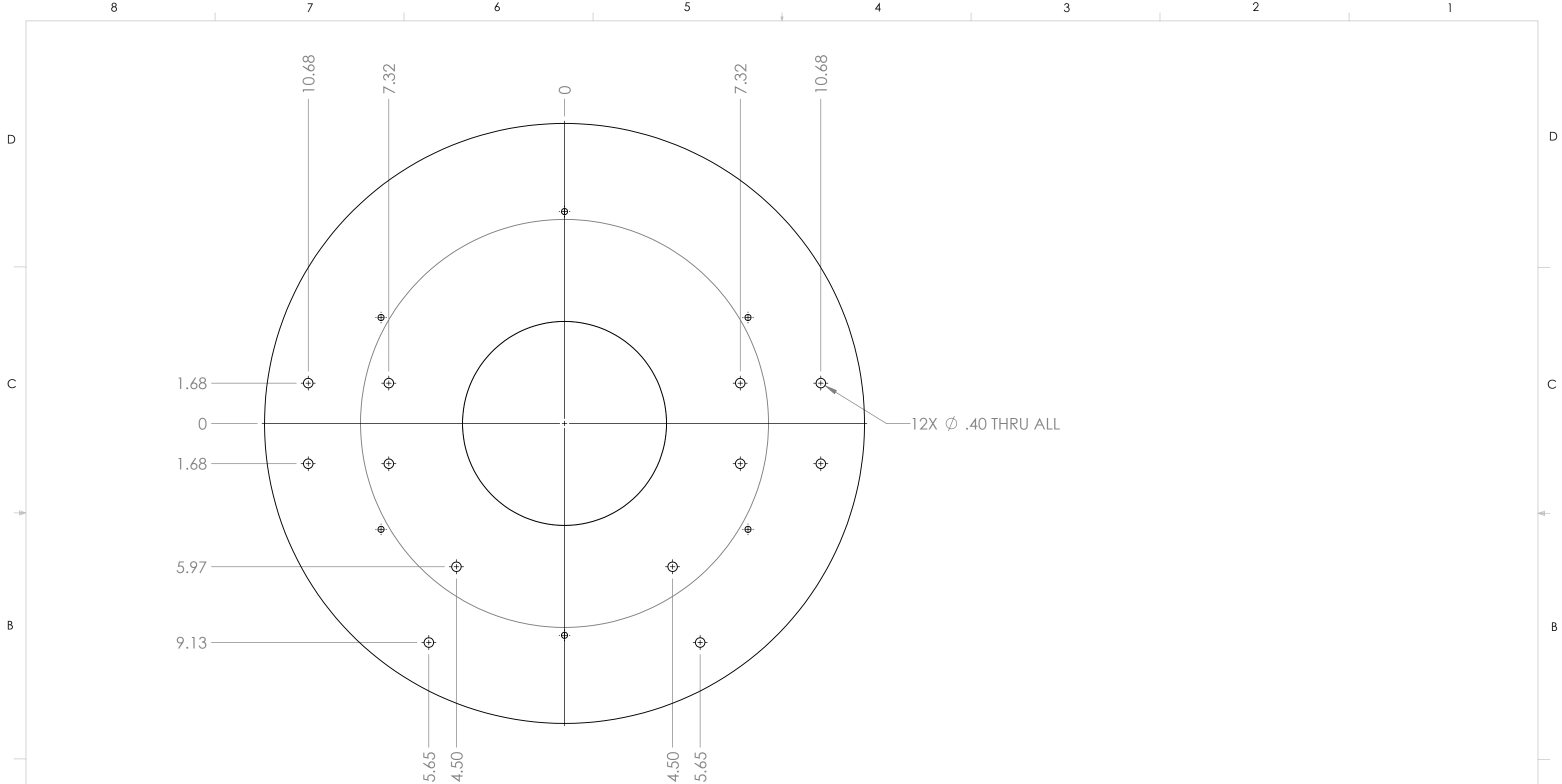

**SolidWorks Educational Edition.
For Instructional Use Only.**

PROPRIETARY AND CONFIDENTIAL
THE INFORMATION CONTAINED IN THIS DRAWING IS THE SOLE PROPERTY OF RIT-KGCOE. ANY REPRODUCTION IN PART OR AS A WHOLE WITHOUT THE WRITTEN PERMISSION OF RIT-KGCOE IS PROHIBITED.

		UNLESS OTHERWISE SPECIFIED:		NAME	DATE	RIT MSD Jib Transfer Bench			
		DIMENSIONS ARE IN INCHES		DRAWN	MJB			4/19/14	
		TOLERANCES:		CHECKED			TITLE:		
		ANGULAR: MACH ±3deg		ENG APPR.			UpperBase_3		
		TWO PLACE DECIMAL ±0.01		MFG APPR.			SIZE	DWG. NO.	REV
		THREE PLACE DECIMAL ±0.001		Q.A.			B	Base_Upper	
		INTERPRET GEOMETRIC TOLERANCING PER:		COMMENTS:			SCALE: 1:4	WEIGHT:	SHEET 4 OF 7
	NEXT ASSY		USED ON						
	APPLICATION		DO NOT SCALE DRAWING						

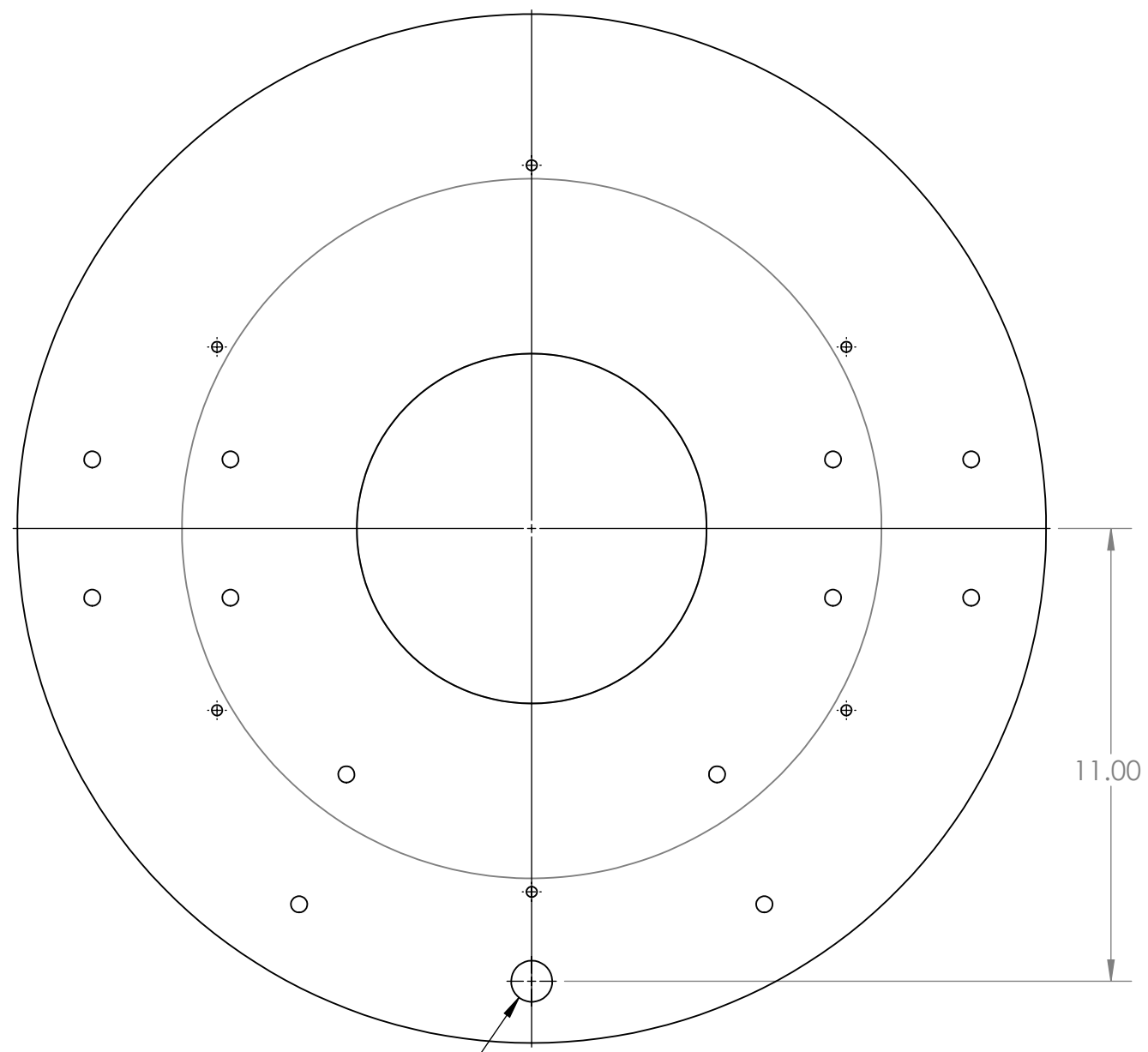

FOLLOW SPECIAL INSTRUCTIONS FOR DRILLING

		UNLESS OTHERWISE SPECIFIED:	NAME	DATE	RIT MSD Jib Transfer Bench			
		DIMENSIONS ARE IN INCHES	DRAWN	MJB			4/19/14	
		TOLERANCES:	CHECKED			TITLE:		
		ANGULAR: MACH ±3deg	ENG APPR.			UpperBase_4		
		TWO PLACE DECIMAL ±0.01	MFG APPR.			SIZE	DWG. NO.	REV
		THREE PLACE DECIMAL ±0.001	Q.A.			B	Base_Upper	
		INTERPRET GEOMETRIC TOLERANCING PER:	COMMENTS:			SCALE: 1:4	WEIGHT:	SHEET 5 OF 7
		MATERIAL						
NEXT ASSY	USED ON	FINISH						
APPLICATION		DO NOT SCALE DRAWING						

**SolidWorks Educational Edition.
For Instructional Use Only.**

PROPRIETARY AND CONFIDENTIAL
THE INFORMATION CONTAINED IN THIS DRAWING IS THE SOLE PROPERTY OF RIT-KGCOE. ANY REPRODUCTION IN PART OR AS A WHOLE WITHOUT THE WRITTEN PERMISSION OF RIT-KGCOE IS PROHIBITED.

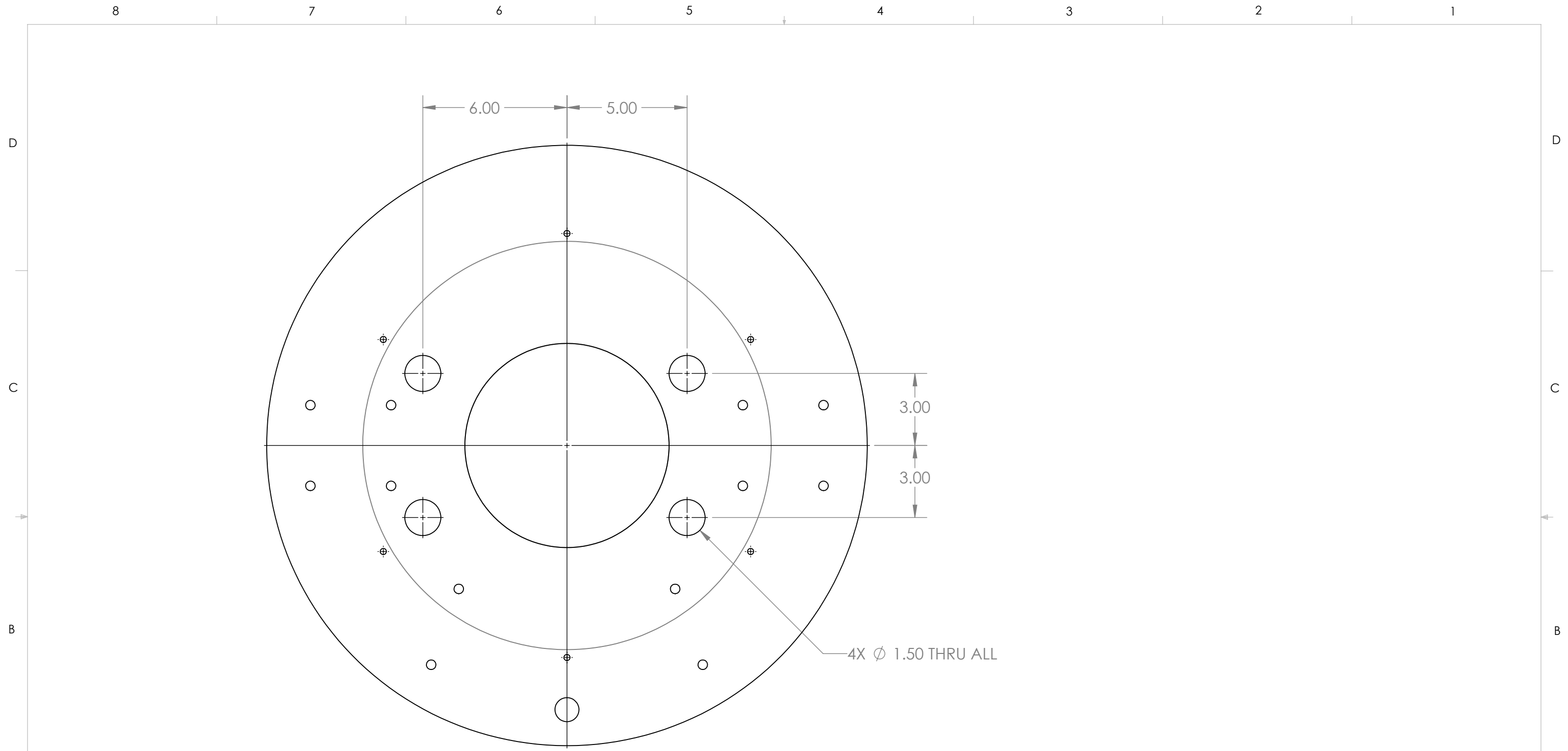

**SolidWorks Educational Edition.
For Instructional Use Only.**

PROPRIETARY AND CONFIDENTIAL
THE INFORMATION CONTAINED IN THIS DRAWING IS THE SOLE PROPERTY OF RIT-KGCOE. ANY REPRODUCTION IN PART OR AS A WHOLE WITHOUT THE WRITTEN PERMISSION OF RIT-KGCOE IS PROHIBITED.

		UNLESS OTHERWISE SPECIFIED:		NAME	DATE	RIT MSD Jib Transfer Bench	
		DIMENSIONS ARE IN INCHES		DRAWN	MJB		
		TOLERANCES:		CHECKED		TITLE: UpperBase_5	
		ANGULAR: MACH ±3deg		ENG APPR.			
		TWO PLACE DECIMAL ±0.01		MFG APPR.		SIZE DWG. NO. REV B Base_Upper	
		THREE PLACE DECIMAL ±0.001		Q.A.			
		INTERPRET GEOMETRIC TOLERANCING PER:		COMMENTS:		SCALE: 1:4 WEIGHT: SHEET 6 OF 7	
		MATERIAL					
NEXT ASSY	USED ON	FINISH					
APPLICATION		DO NOT SCALE DRAWING					

8 7 6 5 4 3 2 1

D
C
B
A

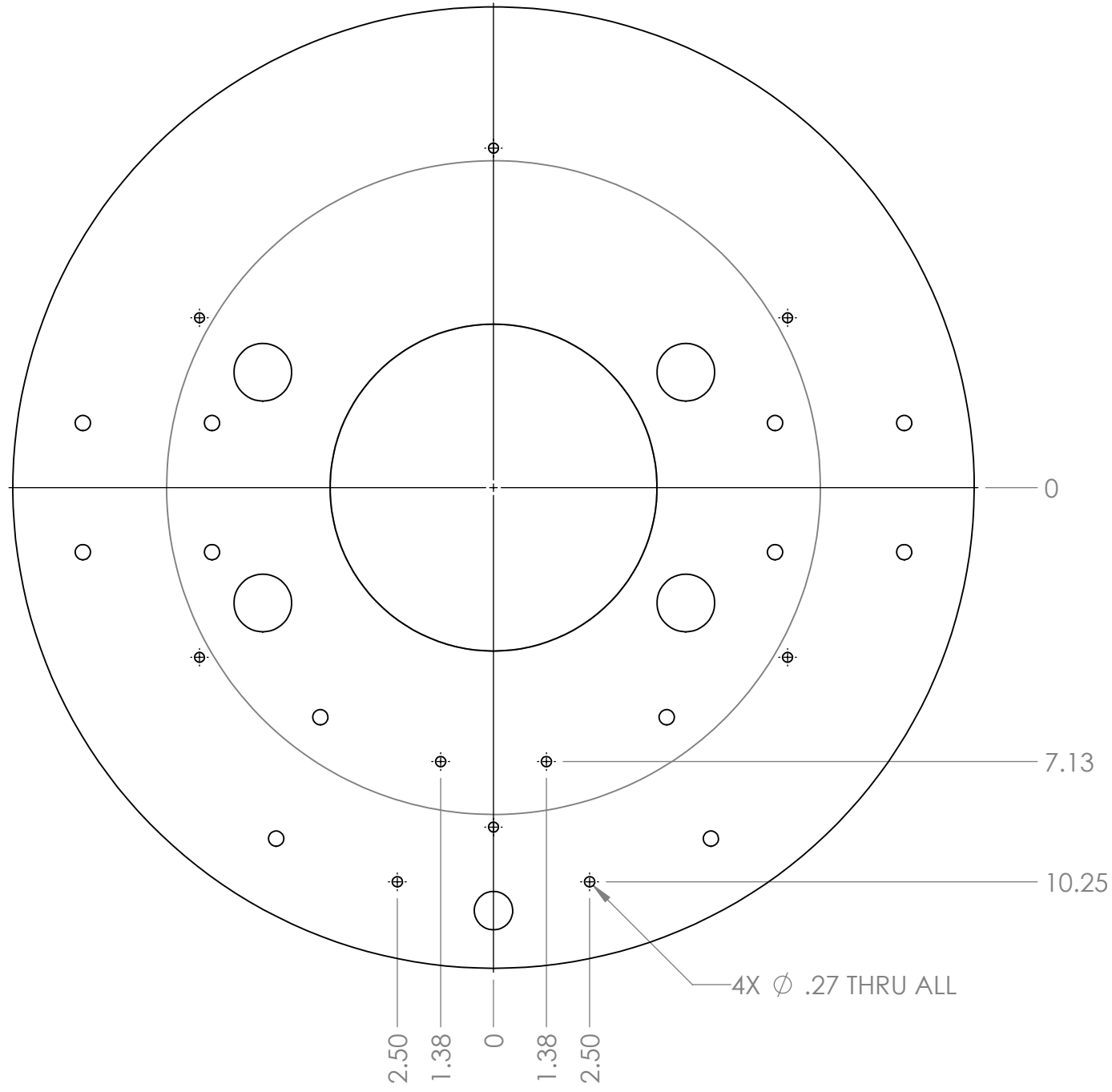

**SolidWorks Educational Edition.
For Instructional Use Only.**

PROPRIETARY AND CONFIDENTIAL
THE INFORMATION CONTAINED IN THIS DRAWING IS THE SOLE PROPERTY OF RIT-KGCOE. ANY REPRODUCTION IN PART OR AS A WHOLE WITHOUT THE WRITTEN PERMISSION OF RIT-KGCOE IS PROHIBITED.

		UNLESS OTHERWISE SPECIFIED:		NAME	DATE	RIT MSD Jib Transfer Bench		
		DIMENSIONS ARE IN INCHES TOLERANCES: ANGULAR: MACH ±3deg TWO PLACE DECIMAL ±0.01 THREE PLACE DECIMAL ±0.001		DRAWN	MJB			4/19/14
		INTERPRET GEOMETRIC TOLERANCING PER:		CHECKED		TITLE:		
		MATERIAL		ENG APPR.		UpperBase_6		
		FINISH		MFG APPR.				
NEXT ASSY	USED ON			Q.A.		SIZE	DWG. NO.	REV
APPLICATION		DO NOT SCALE DRAWING		COMMENTS:		B Base_Upper		
						SCALE: 1:4	WEIGHT:	SHEET 7 OF 7

8 7 6 5 4 3 2 1

8 7 6 5 4 3 2 1

D

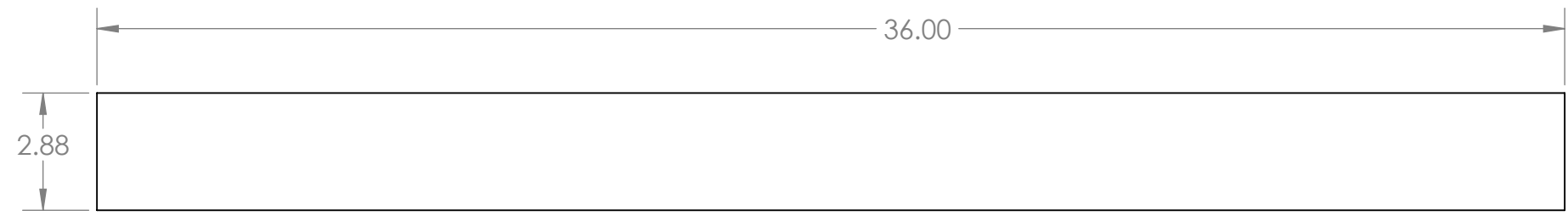
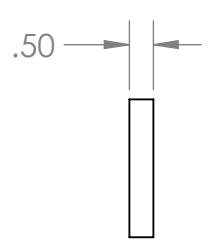

C

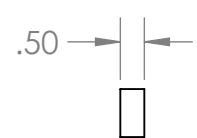

B

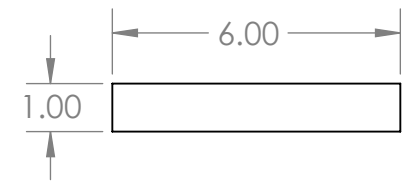
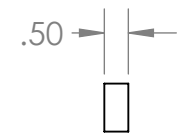

A

**SolidWorks Educational Edition.
For Instructional Use Only.**

PROPRIETARY AND CONFIDENTIAL
THE INFORMATION CONTAINED IN THIS DRAWING IS THE SOLE PROPERTY OF RIT-KGCOE. ANY REPRODUCTION IN PART OR AS A WHOLE WITHOUT THE WRITTEN PERMISSION OF RIT-KGCOE IS PROHIBITED.

PART NAME	LENGTH	QTY IN ASSY
Base_uprights	36"	2
12-strip	12"	1
6-strip	6"	1

		UNLESS OTHERWISE SPECIFIED:		NAME	DATE	RIT MSD Jib Transfer Bench TITLE:
		DIMENSIONS ARE IN INCHES TOLERANCES: ANGULAR: MACH ±3deg TWO PLACE DECIMAL ±0.01 THREE PLACE DECIMAL ±0.001		DRAWN	MJB 12/18/13	
		INTERPRET GEOMETRIC TOLERANCING PER:		CHECKED		
		MATERIAL MARINE PLYWOOD		ENG APPR.		
		FINISH		MFG APPR.		
NEXT ASSY	USED ON			Q.A.		SIZE DWG. NO. REV
APPLICATION		DO NOT SCALE DRAWING		COMMENTS:		Base_uprights
						SCALE: 1:4 WEIGHT: SHEET 1 OF 1

8 7 6 5 4 3 2 1

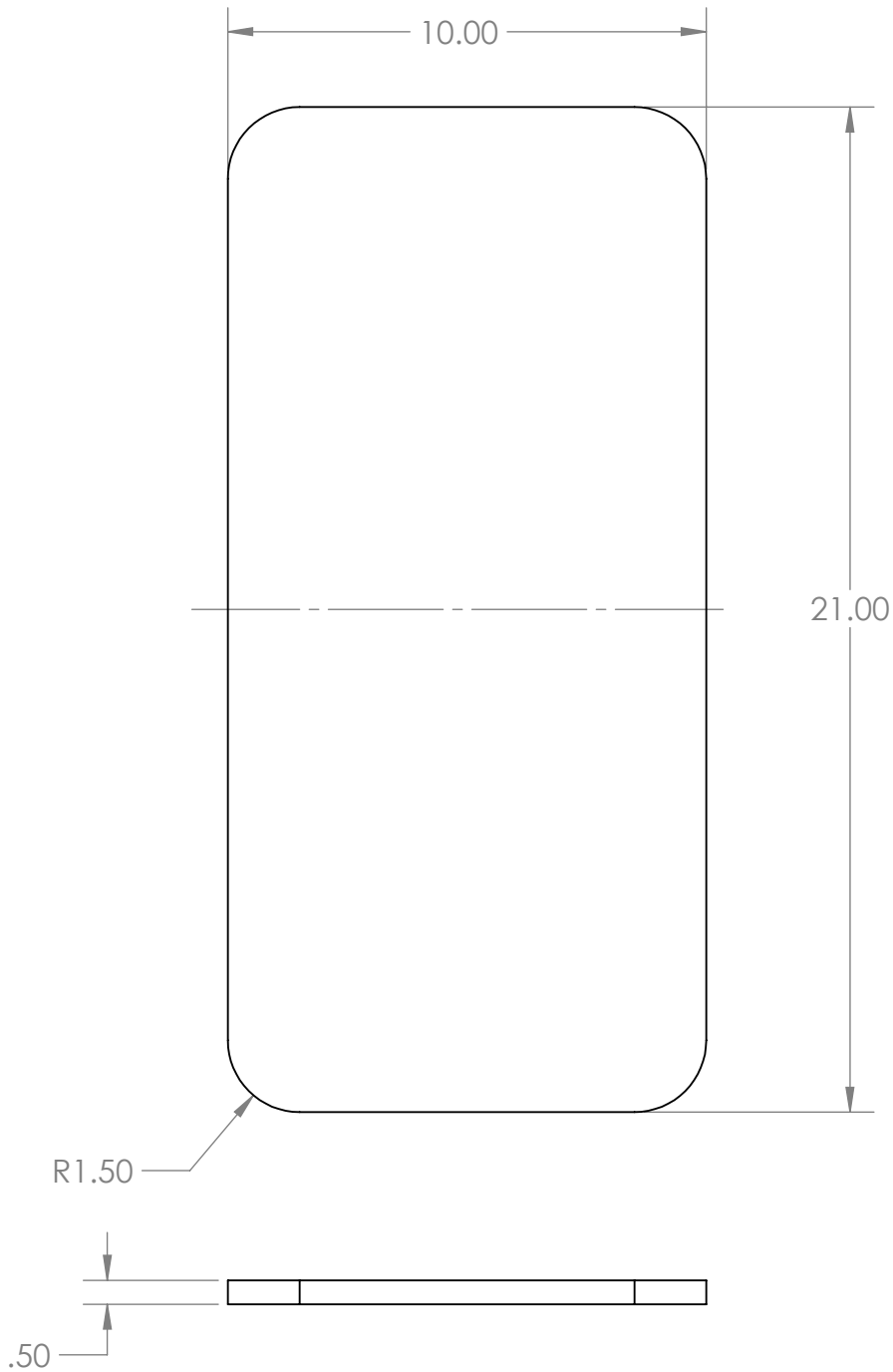

PROPRIETARY AND CONFIDENTIAL
 THE INFORMATION CONTAINED IN THIS DRAWING IS THE SOLE PROPERTY OF RIT-KGCOE. ANY REPRODUCTION, IN PART OR AS A WHOLE WITHOUT THE WRITTEN PERMISSION OF RIT-KGCOE IS PROHIBITED.

SolidWorks Educational Edition.
For Instructional Use Only.

DIMENSIONS ARE IN INCHES	
TOLERANCES:	
ANGULAR: MACH ±3deg	
TWO PLACE DECIMAL ±0.01	
THREE PLACE DECIMAL ±0.001	
NEXT ASSY	USED ON
APPLICATION	DO NOT SCALE DRAWING

NAME	DATE
DRAWN MJB	4/15/14
CHECKED	
ENG APPR.	
MFG APPR.	
Q.A.	
COMMENTS:	

RIT MSD Jib Transfer Bench

SIZE	DWG. NO.	REV.
A	Seat_Base	
SCALE: 1:4	WEIGHT:	SHEET 1 OF 1

MATERIAL: MARINE PLYWOOD
 FINISH:

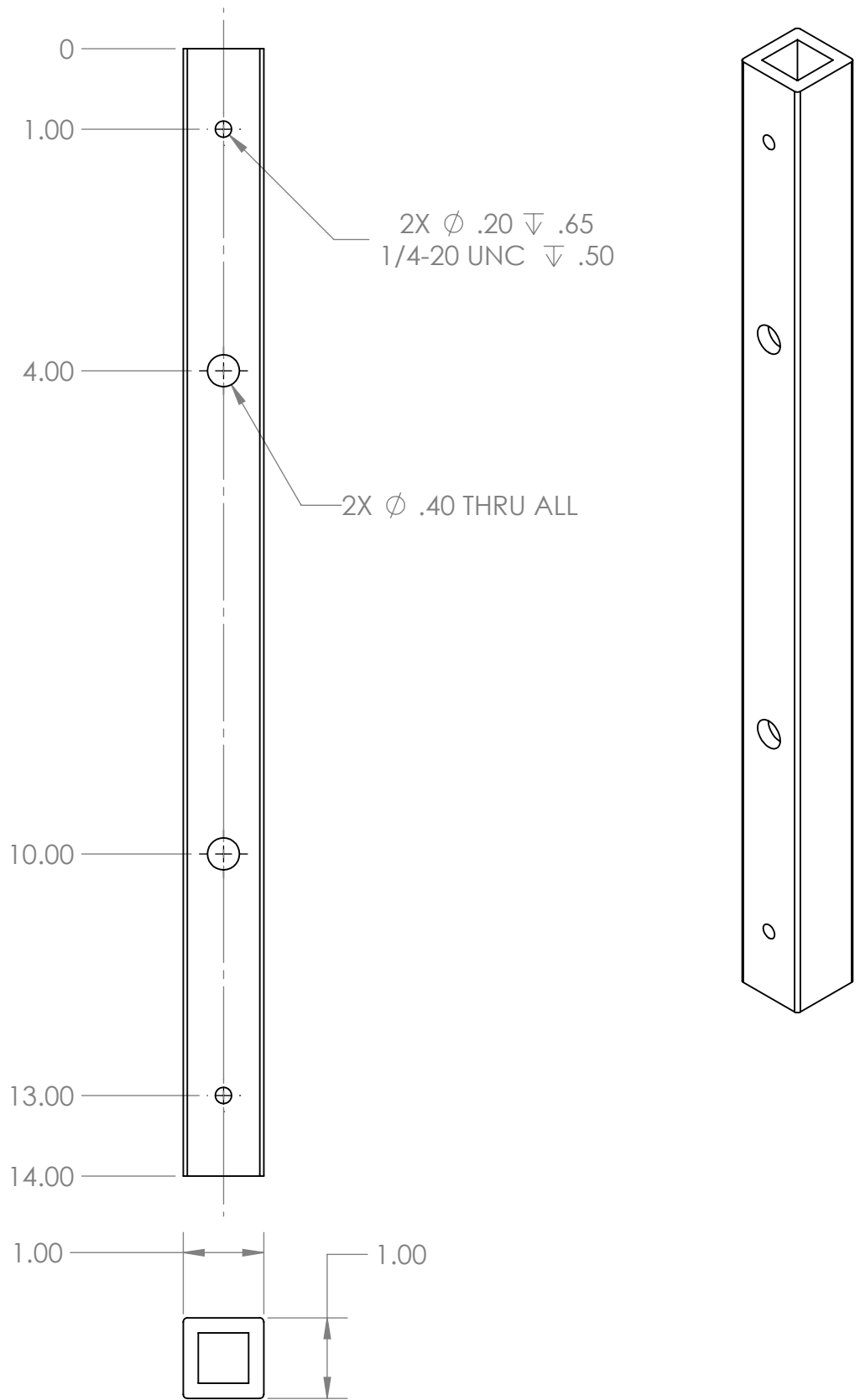

PROPRIETARY AND CONFIDENTIAL
 THE INFORMATION CONTAINED IN THIS
 DRAWING IS THE SOLE PROPERTY OF
 RIT-KGCOE. ANY REPRODUCTION,
 PART OR AS A WHOLE WITHOUT THE
 WRITTEN PERMISSION OF
 RIT-KGCOE IS PROHIBITED.

SolidWorks Educational Edition.
For Instructional Use Only.

DIMENSIONS ARE IN INCHES	
TOLERANCES:	
ANGULAR: MACH±3deg	
TWO PLACE DECIMAL ±0.01	
THREE PLACE DECIMAL ±0.001	
MATERIAL	1 1/2" x 1/8" WALL AL-SQ-TUBE
FINISH	
NEXT ASSY	USED ON
APPLICATION	DO NOT SCALE DRAWING

NAME	MJB	DATE	12/18/13
DRAWN			
CHECKED			
ENG APPR.			
MFG APPR.			
Q.A.			
COMMENTS:			

RIT MSD Jib Transfer Bench		
SIZE	DWG. NO.	REV.
A	Lower_Clamp_Bar	
SCALE:1:2	WEIGHT:	SHEET 1 OF 1

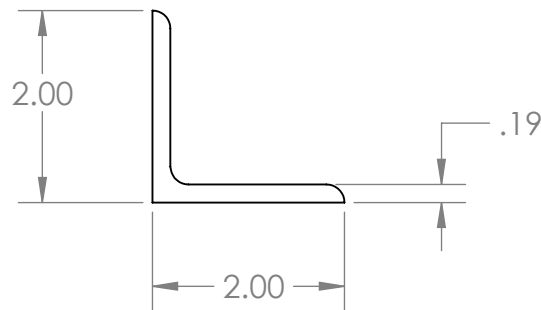
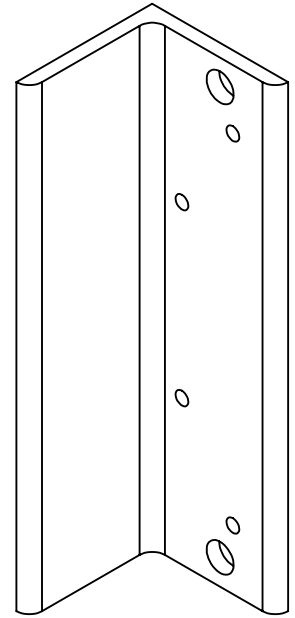
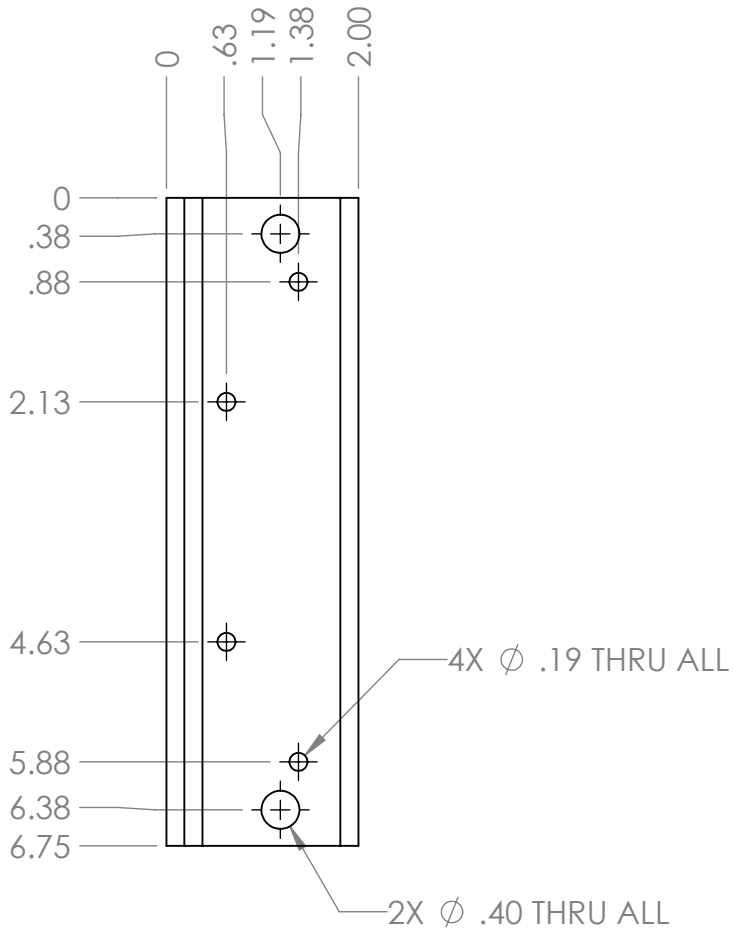

PROPRIETARY AND CONFIDENTIAL
 THE INFORMATION CONTAINED IN THIS
 DRAWING IS THE SOLE PROPERTY OF
 RIT-KGCOE. ANY REPRODUCTION,
 PART OR AS A WHOLE WITHOUT THE
 WRITTEN PERMISSION OF
 RIT-KGCOE IS PROHIBITED.

SolidWorks Educational Edition.
For Instructional Use Only.

DIMENSIONS ARE IN INCHES TOLERANCES: ANGULAR: MACH±3deg TWO PLACE DECIMAL ±0.01 THREE PLACE DECIMAL ±0.001	
NEXT ASSY	USED ON
APPLICATION	DO NOT SCALE DRAWING

NAME	DATE
DRAWN MJB	12/18/13
CHECKED	
ENG APPR.	
MFG APPR.	
Q.A.	
COMMENTS:	

RIT MSD Jib Transfer Bench

SIZE	DWG. NO.	REV.
A	Base_AngleStock	
SCALE:1:2	WEIGHT:	SHEET 1 OF 1

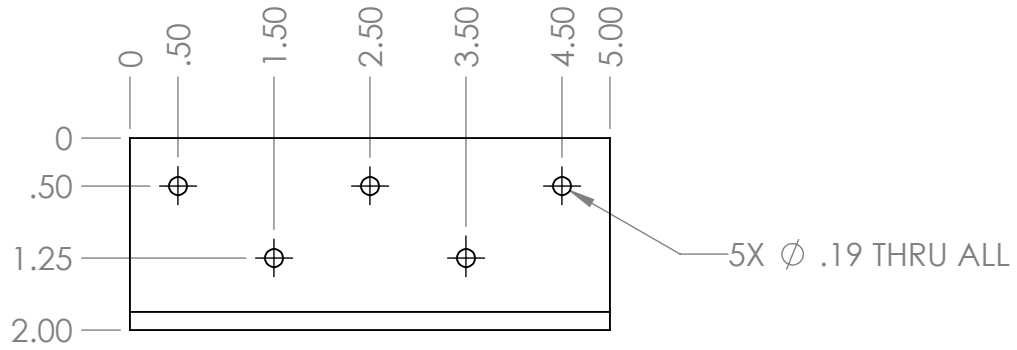
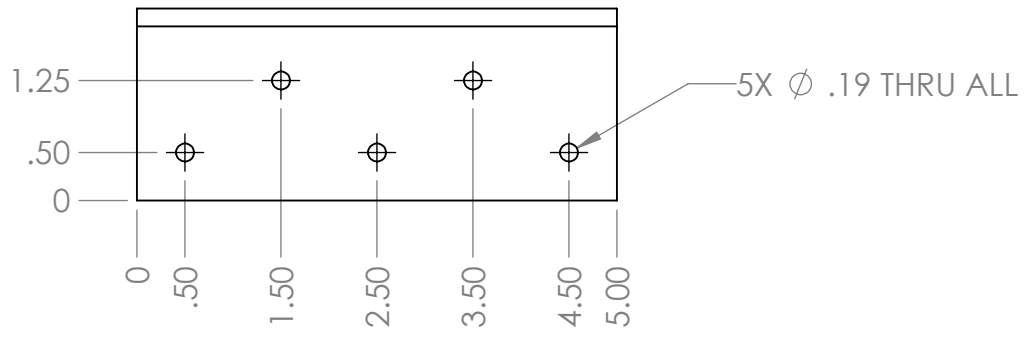
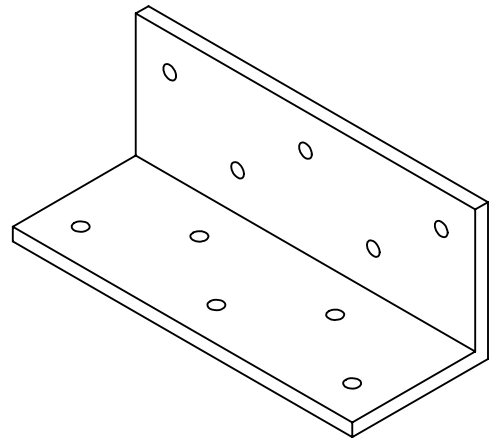

PROPRIETARY AND CONFIDENTIAL
 THE INFORMATION CONTAINED IN THIS
 DRAWING IS THE SOLE PROPERTY OF
 RIT-KGCOE. ANY REPRODUCTION,
 PART OR AS A WHOLE WITHOUT THE
 WRITTEN PERMISSION OF
 RIT-KGCOE IS PROHIBITED.

SolidWorks Educational Edition.
For Instructional Use Only.

		DIMENSIONS ARE IN INCHES TOLERANCES: ANGULAR: MACH±3deg TWO PLACE DECIMAL ±0.01 THREE PLACE DECIMAL ±0.001		NAME	DATE	RIT MSD Jib Transfer Bench
		MATERIAL		DRAWN	MJB 4/22/14	
		FINISH		CHECKED		
		NEXT ASSY		ENG APPR.		
		USED ON		MFG APPR.		
		APPLICATION		Q.A.		
		DO NOT SCALE DRAWING		COMMENTS:		
				SCALE:1:2	WEIGHT:	REV.
				SIZE DWG. NO. A Base_Upright_Support		
						SHEET 1 OF 1