

1. HOLES AND FINAL PROFILE WILL BE DONE IN CNC
2. QTY 2 MEANS 1 PER PRINT AND 1 MIRRORED

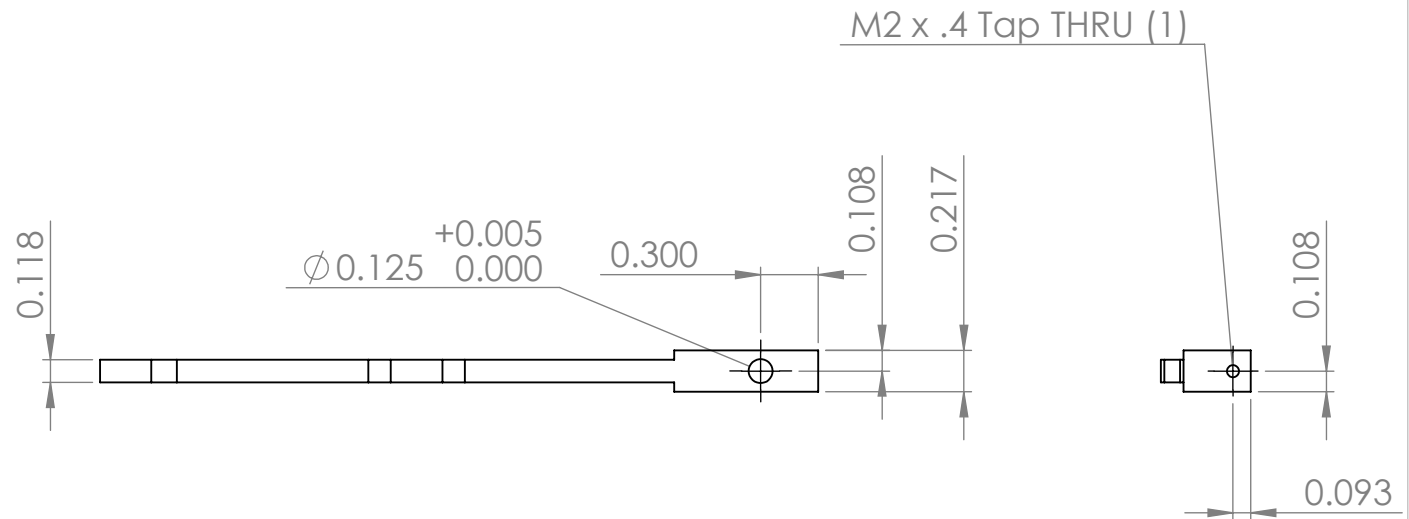
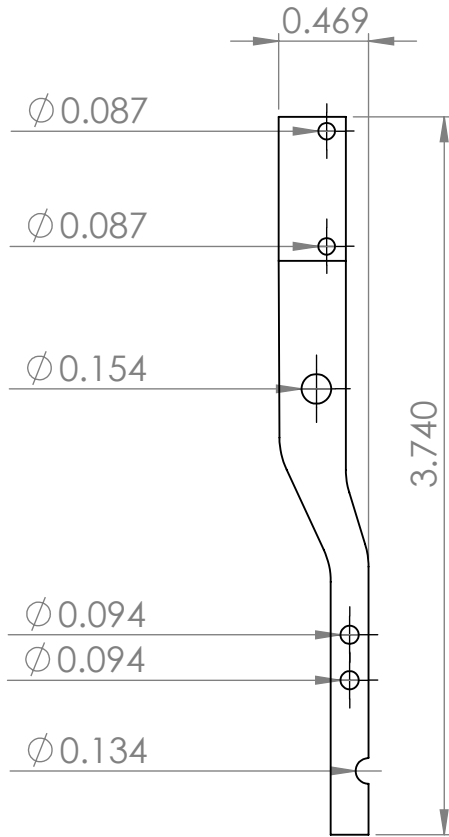
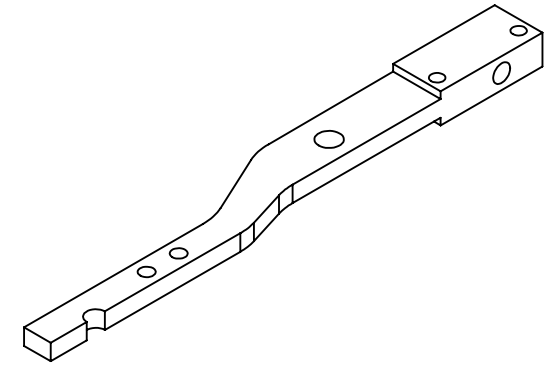

DIMENSIONS ARE IN INCHES TOLERANCES: FRACTIONAL $\pm 1/16$ ANGULAR: MACH ± 1 BEND ± 2 TWO PLACE DECIMAL $\pm .01$ THREE PLACE DECIMAL $\pm .005$	TEAM #	P20129	
	TEAM NAME	F.R.OH.S.T.	
	OWNER	MATTHEW DAVERN	
	DATE MODIFIED	THURSDAY, JANUARY 23, 2020	
	SUBSYSTEM	ARM BEARING	
MATERIAL	CONTACT PHONE		Senior Design SIZE Part Name/# A ARM REV2B SCALE:1:1 WEIGHT: SHEET 1 OF 1
FINISH	COMMENTS:		
	QUANTITY: 2		